



June 15, 2003
Lit. No. 27097

MECHANIC'S GUIDE



SNOWPLOWS
Featuring the
FloStat® Hydraulic System

⚠ CAUTION

Read this manual before servicing the snowplow.



TABLE OF CONTENTS

PREFACE

Preface	2
Safety Information	4
FloStat® Hydraulic System	6
Product Specifications and Required Tools	6
Hydraulic Hose Routing and Fitting Orientation	7
Hydraulic Unit Parts Diagram	8
Hydraulic Unit Valve Identification and Location	9
Relief Valve Identification and Location	10
Check Valve Identification and Location	11
Vehicle Harness and Vehicle Cable Diagram	12
Operating the Snowplow	13
Theory of Operation	15
Hydraulic and Electrical Schematics	16
Raise	20
Lower	22
Angle Right	24
Angle Left	26
Hold in Raised Position	28
Striking An Object While Plowing	29
Headlamps – Plow Not Connected	31
High Beam Headlamps With Plow Connected to Vehicle	33
Low Beam Headlamps With Plow Connected to Vehicle	35
Troubleshooting Guide	37

This guide has been prepared to assist the trained mechanic in the service of WESTERN® snowplows. It also provides safety information and recommendations. We urge all mechanics to read this manual carefully before attempting to service the WESTERN snowplow equipment covered by this guide.

Service of your WESTERN snowplow equipment is best performed by your local Western Products outlet. They know your snowplow best and are interested in your complete satisfaction.

SAFETY INFORMATION

⚠ WARNING

Indicates a potentially hazardous situation that, if not avoided, could result in death or serious personal injury.

⚠ CAUTION

Indicates a situation that, if not avoided, could result in damage to product or property.

NOTE: Identifies tips, helpful hints and maintenance information the owner/operator should know.

BEFORE YOU BEGIN

⚠ WARNING

Lower blade when vehicle is parked. Temperature changes could change hydraulic pressure, causing the blade to drop unexpectedly or damaging hydraulic components. Failure to do this can result in serious personal injury.

⚠ WARNING

Do not exceed GVWR or GAWR including blade and ballast. The rating label is found on the driver-side vehicle door cornerpost.

Please become familiar with and make owners knowledgeable of the Warning and Instruction labels on the back of the blade!

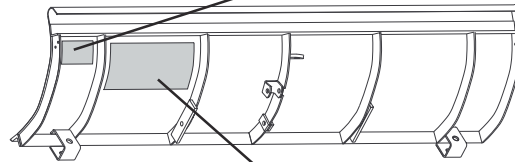

Warning and Caution Label

⚠ WARNING

LOWER BLADE WHEN VEHICLE IS PARKED.
REMOVE BLADE ASSEMBLY BEFORE PLACING VEHICLE ON HOIST.
DO NOT EXCEED GVWR OR GAWR INCLUDING BLADE AND BALLAST.

⚠ CAUTION

READ OWNER'S MANUAL BEFORE OPERATING OR SERVICING SNOWPLOW.
TRANSPORT SPEED SHOULD NOT EXCEED 45 MPH. REDUCE SPEED UNDER ADVERSE TRAVEL CONDITIONS.
PLOWING SPEED SHOULD NOT EXCEED 10 MPH.
SEE YOUR SALES OUTLET FOR APPLICATION RECOMMENDATIONS.

Instruction Label

INSTRUCTIONS

MOUNTING PLOW (ON)

Read Owner's Manual for complete instructions.

STEP 1

After seating plow horns in receiver brackets, pull Handle up; Shoe will lift off the ground.

STEP 2

Pull and hold Lock Pin out; then rotate Handle UP and release Lock Pin. It must lock into UPPER hole. Stand Hook must grip Receiver Pin.

STEP 3

Plug in electrical connections. Repeat steps 1 and 2 on other side of plow.

STEP 3

Push down top of Shoe; Shoe will be on the ground. Repeat steps 2 and 3 on other side of plow. Back vehicle away.

STEP 2

Pull and hold Lock Pin out; then rotate Handle DOWN and release Lock Pin. It must lock into LOWER hole.

STEP 1

After lowering blade and turning control off, disconnect electrical connections.

REMOVING PLOW (OFF)

Read Owner's Manual for complete instructions.

Patents: US 4,999,935; 5,420,480; RE 35,700; 6,145,232; 6,209,231; 6,253,470; 6,526,677; CAN 2,060,425; patents pending.

SAFETY INFORMATION

BEFORE YOU BEGIN (continued)

WARNING

Remove blade assembly before placing vehicle on hoist.

- Park the vehicle on a level surface, place shift lever in PARK or NEUTRAL and set parking brake.
- Leave the snowplow mounted on the vehicle and lowered for most service procedures, unless told otherwise.

PERSONAL SAFETY

- Wear only snug-fitting clothing while working on your vehicle or snowplow.
- Do not wear jewelry or a necktie, and secure long hair.
- Be especially careful near moving parts such as fan blades, pulleys and belts.
- Wear safety goggles to protect your eyes from battery acid, gasoline, dirt and dust.
- Avoid touching hot surfaces such as the engine, radiator, hoses and exhaust pipes.
- Always have a fire extinguisher handy, rated BC for flammable liquids and electrical fires.

VENTILATION

WARNING

Vehicle exhaust contains deadly carbon monoxide (CO) gas. Breathing this gas, even in low concentrations, could cause death. Never operate a vehicle in an enclosed area without venting exhaust to the outside.

If you work on the vehicle or snowplow in a garage or other enclosed area, be sure to vent exhaust gas directly to the outside through a leakproof exhaust hose.

FIRE AND EXPLOSION

WARNING

Gasoline is highly flammable and gasoline vapor is explosive. Never smoke while working on vehicle. Keep all open flames away from gasoline tank and lines. Wipe up any spilled gasoline immediately.

Be careful when using gasoline. Do not use gasoline to clean parts. Store only in approved containers away from sources of heat or flame.

HYDRAULIC SAFETY

WARNING

Hydraulic oil under pressure could cause skin injection injury. If you are injured by hydraulic oil, get medical attention immediately.

- Always inspect hydraulic components and hoses before using. Replace any damaged or worn parts immediately.
- If you suspect a hose leak, DO NOT use your hand to locate it. Use a piece of cardboard or wood.
- Always loosen plugs, fittings and valves slowly to bleed off any residual pressure.

BATTERY SAFETY

CAUTION

Batteries normally produce explosive gases which can cause personal injury. Therefore, do not allow flames, sparks or lit tobacco to come near the battery. When charging or working near a battery, always cover your face and protect your eyes, and also provide ventilation.

Batteries contain sulfuric acid which burns skin, eyes and clothing.

Disconnect the battery before removing or replacing any electrical components.

PRODUCT SPECIFICATIONS

REQUIRED TOOLS

FloStat® SYSTEM SPECIFICATIONS

⚠ CAUTION

Do not mix different types of hydraulic fluid. Some fluids are not compatible and may cause performance problems and product damage.

Hydraulic System

Hydraulic Oil

- WESTERN® High Performance Fluid to -25°F (-32°C)
- Automatic Transmission Fluid (ATF) DEXRON® III to -10°F (-23°C) or,
- Texaco 1537 Aircraft Hydraulic Oil for temperatures below -25° F (-32°C).

Fluid Capacity – Hydraulic Oil

- Unit Reservoir = 1 3/4 Quarts
- System Total:
w/ 10" Ram = 2-3/8 to 2-3/4 Quarts: Standard & Pro

Solenoid Valve Spool Travel = 0.07" for three- and four-way valves (S2, S3)

Electrical System – approximate values:

- Solenoid Valve Coil Resistance = 6.7 Ohms at room temperature
- Solenoid Valve Coil Amp. Draw = 1.5 Amp.

- Motor Relay Coil Resistance = 16 - 17 Ohms
- Motor Relay Amp. Draw = 0.7 Amp.
- Headlamp Relay Coil Resistance = 106 Ohms
- Headlamp Relay Amp Draw = 0.1 Amp.

Fuse Size

- Harness – 6 Amp. (SFE-6)

Mechanical

Fastener Torque in IN-LB	
Pump Cap Screws	150 – 160
Motor Terminal Nuts.....	50 – 60
Motor to Manifold Cap Screws	30 – 40
Reservoir Screws	15 – 20
Valve Cartridges.....	115 – 125
Coil Nuts.....	48 – 60
Cartridge / Coil Cover Screws	15 – 20
O-ring Boss Plug.....	60 – 70

Tools Required for servicing the electrical and hydraulic systems:

- Long/Slender Needle Nose Pliers
- Flat Screwdriver
- Sockets and Combination Wrenches: 3/8" thru 7/8", 1-1/16", 1-1/8", 2-3/16"
- 2-3/16" open end wrench
- Deep Socket: 7/8"
- 1/4" Socket or Nut Driver
- 12 V Test Light
- Torque Wrench (in-lb)
- Allen Wrench Set
- 3000 PSI Pressure Gauge w/adaptor fittings
- Flashlight
- Pick Set
- Hammer
- Digital Volt/Ohm Meter
- Pencil Magnet

Available from your WESTERN® outlet:

- UniMount®/UltraMount® Electrical Tester
- Pressure Test Kit

Plow Type	Crossover Relief Valve Pressure (± 100 PSI)	No. of Turns Crossover Relief Valve Is Backed Off (CCW) From Fully Seated*	Pump Relief Valve Pressure (± 50 PSI)	No. of Turns Pump Relief Valve Is Backed Off (CCW) From Fully Seated*	Max. Motor Amp Draw At Relief Pressure**
Standard, Pro, PRO PLUS™	4000	1-1/4 – 1-1/2	1750	2-1/2 – 2-3/4	200

* Settings are approximate.

** Actual readings may vary due to vehicle battery voltage and oil temperature.

FloStat® HYDRAULIC HOSE ROUTING AND FITTING INSTALLATION

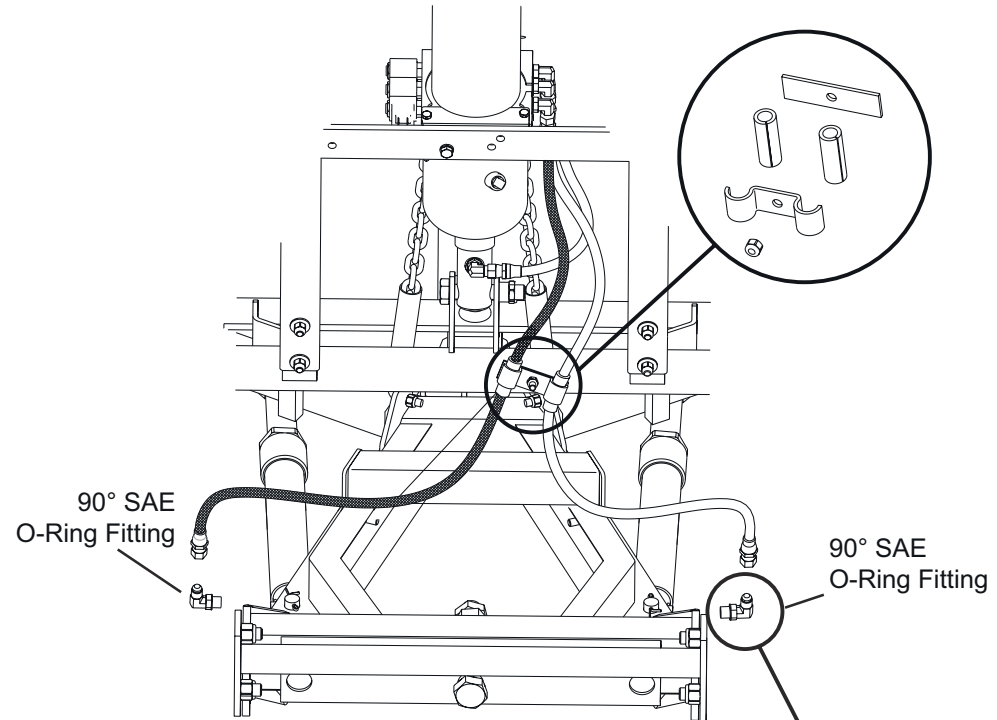
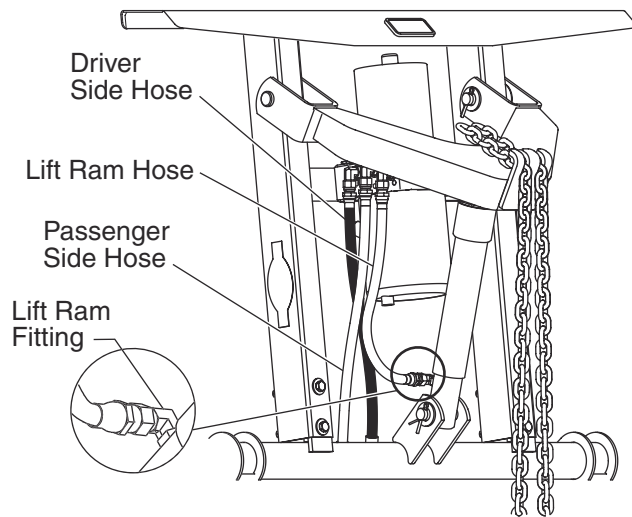

Use the following procedure to install **SAE O-Ring fittings** in valve blocks and rams:

Back off jam nut. Hand tighten fitting into port until washer contacts port face, then back out to position. Using two wrenches, hold fitting body in position and tighten jam nut until the washer again contacts port face, then tighten additional 1/8 to 1/4 turn to lock fittings in place. Final torque on the jam nut should be approximately 20 ft.-lbs .

Use the following procedure to install **hydraulic hoses**:

Using two wrenches, hold the hose in position and tighten flare nut 1/8 to 1/4 turn beyond hand tight. Final torque on the flare nut should be approximately 20 ft.-lbs.

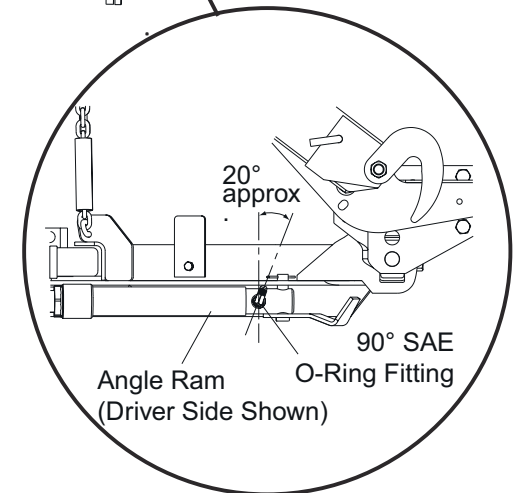

FloStat® HYDRAULIC UNIT PARTS DIAGRAM

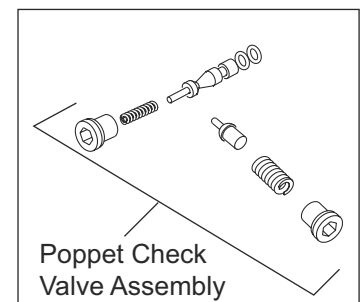
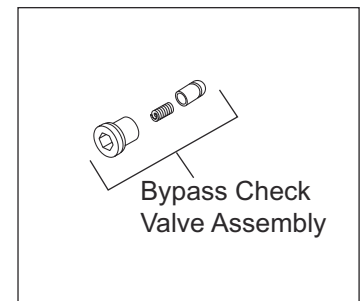
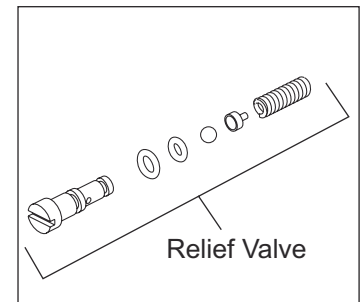
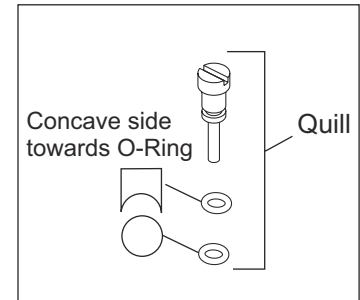
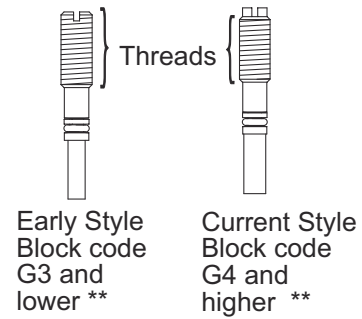
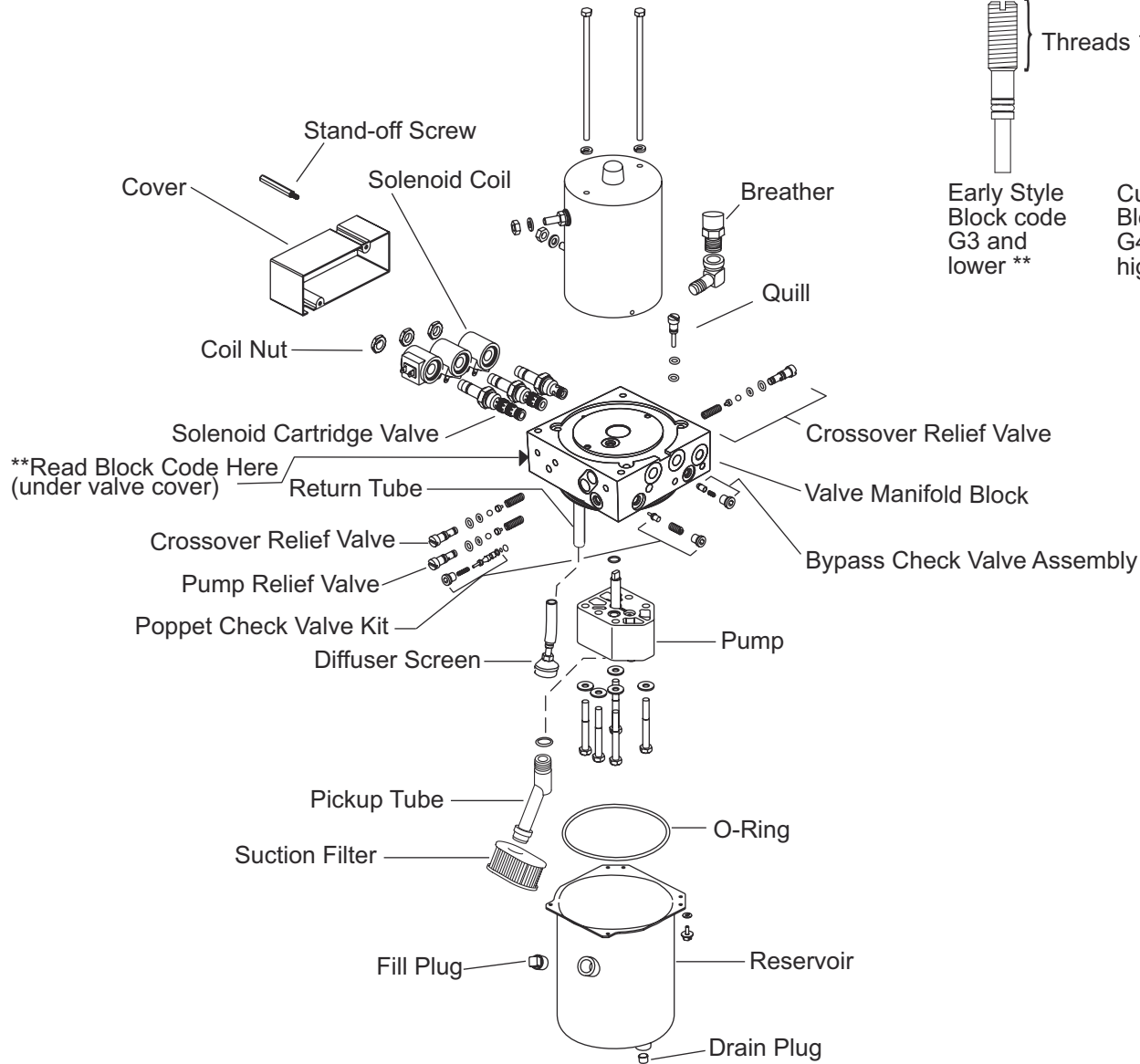

FloStat® HYDRAULIC UNIT VALVE IDENTIFICATION AND LOCATION

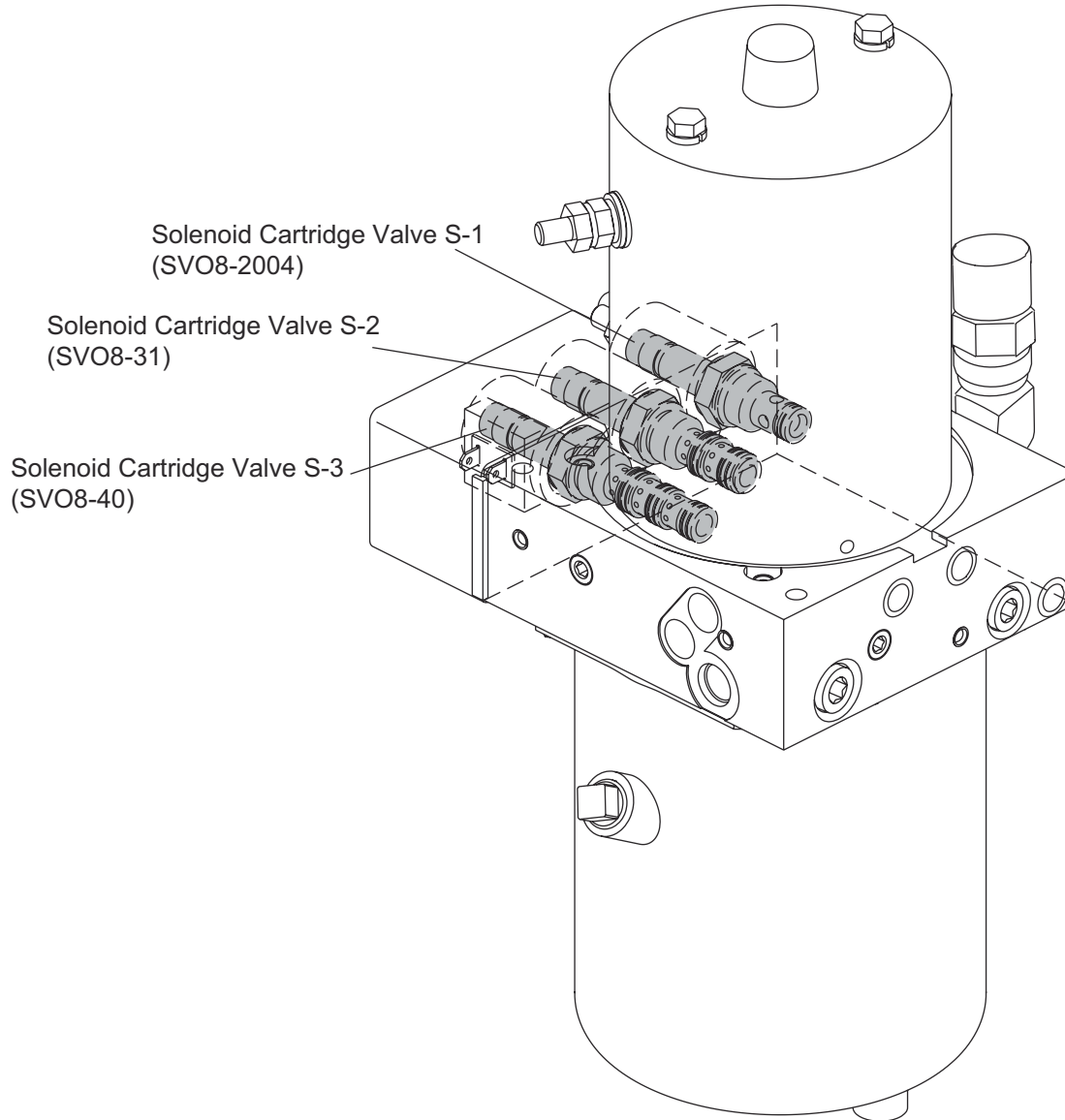

NOTE: Breather is located at front of FloStat® hydraulic unit.

RELIEF VALVE IDENTIFICATION AND LOCATION

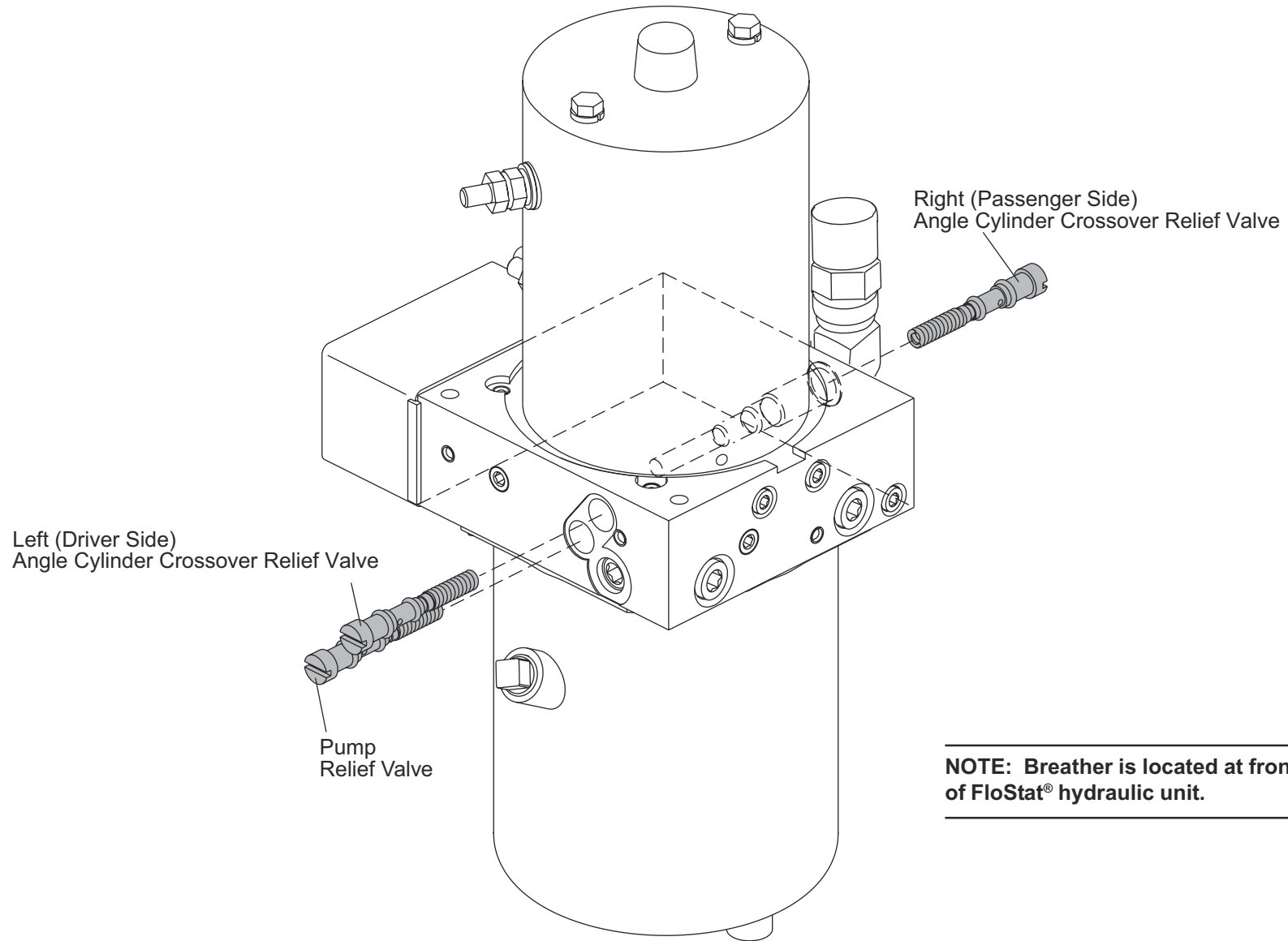

NOTE: Breather is located at front of FloStat® hydraulic unit.

PILOT-OPERATED (POPPET TYPE) CHECK VALVE IDENTIFICATION AND LOCATION

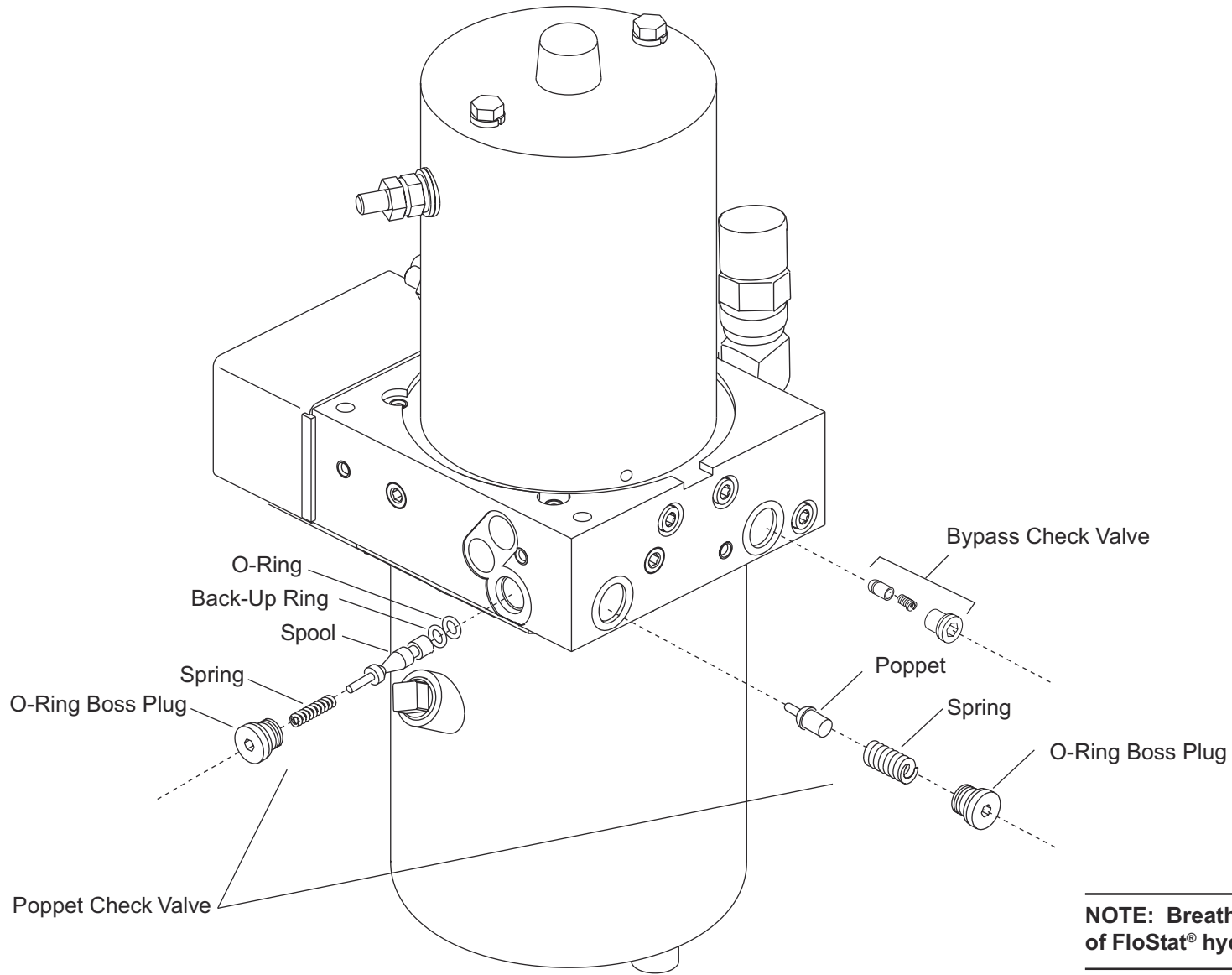

NOTE: Breather is located at front of FloStat® hydraulic unit.

VEHICLE HARNESS AND VEHICLE CABLE DIAGRAM

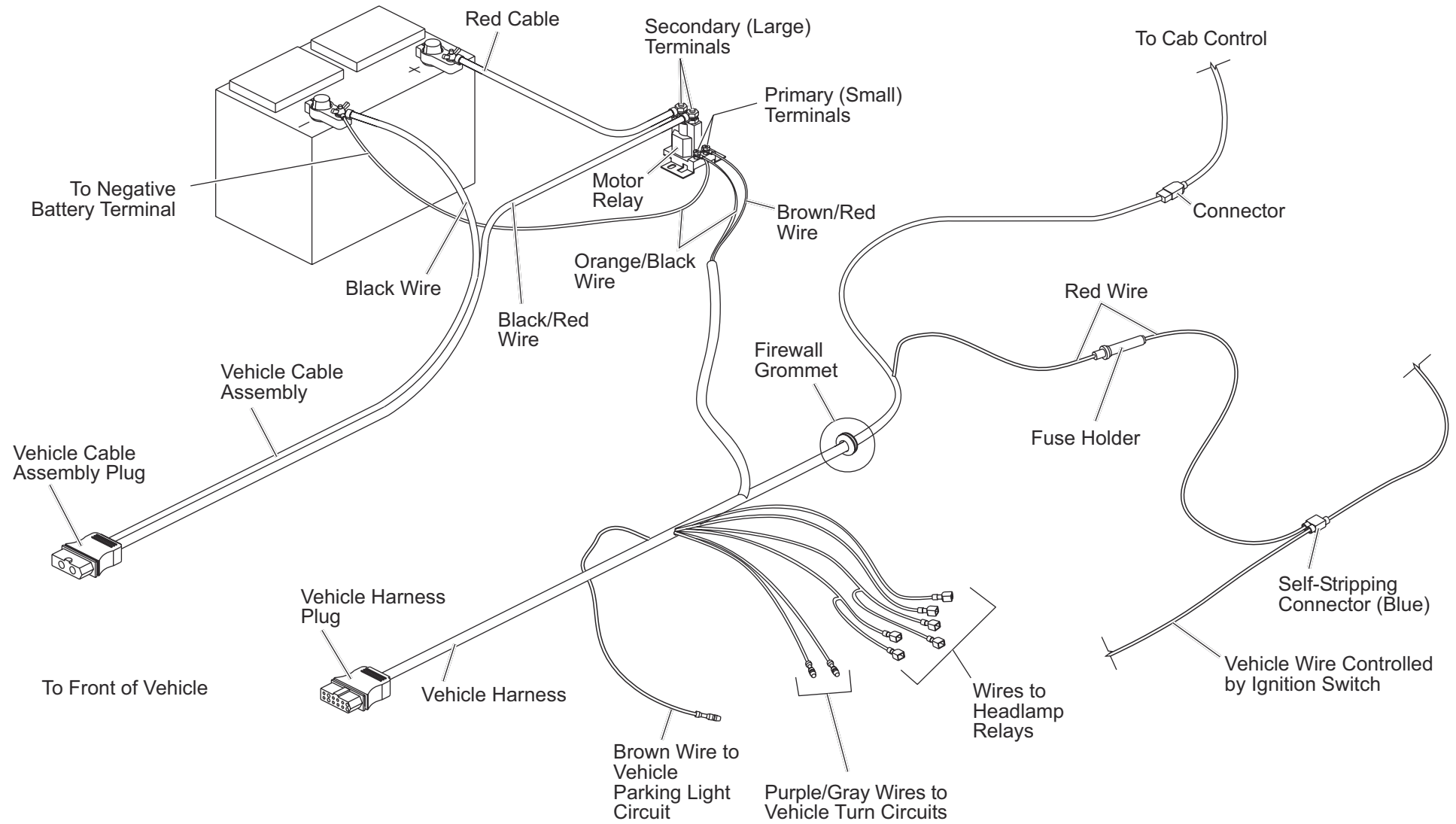

OPERATING THE SNOWPLOW

SOLENOID CONTROL

⚠ WARNING

The driver shall keep bystanders clear of the blade when it is being raised, lowered or angled. Do not stand between the vehicle and the blade, or within 8 feet of a moving blade. A moving or falling blade could cause personal injury.

⚠ CAUTION

To prevent accidental movement of the blade, always turn the ON/OFF switch to OFF whenever the snowplow is not in use. The control indicator light will turn off.

Turn the vehicle ignition switch to the ON or the ACCESSORY position. Move control ON/OFF switch to the ON position. The control indicator light (red) should light whenever the control ON/OFF switch and the ignition (key) are both turned ON.

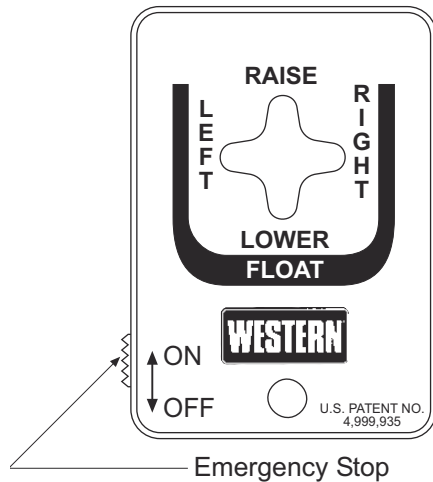

Turn the vehicle ignition switch on. Turn the control on. The control indicator light should be on.	
Action	Description of Operation
ON/OFF	Slide the control power switch ON to activate the hydraulic system. Turn the control OFF to lock the blade in place. This will prevent accidental movement of the blade.
Raise	Move the control lever up (forward) to raise the blade to the desired height.
Lower/Float	Move the control lever down (back) to lower the blade and activate the FLOAT mode.
To Cancel FLOAT	The FLOAT mode can be canceled by either momentarily placing the control in the RAISE position, turning the control off or turning the vehicle ignition off. Angling left or right will not cancel float.
Right	Move the control lever right to angle the blade to the right.
Left	Move the control lever left to angle the blade to the left.

OPERATING THE SNOWPLOW

CABCOMMAND HAND-HELD CONTROL

⚠ WARNING

The driver shall keep bystanders clear of the blade when it is being raised, lowered or angled. Do not stand between the vehicle and the blade, or within 8 feet of a moving blade. A moving or falling blade could cause personal injury.

⚠ CAUTION

To prevent accidental movement of the blade, always turn the ON/OFF switch to OFF whenever the snowplow is not in use. The control indicator light will turn off.

1. Turn the vehicle ignition switch to the ON or the ACCESSORY position. The controller logo area will become illuminated.
2. Press the ON/OFF button on the control. The control indicator light will glow red indicating the control is on. The control indicator light

will glow red whenever the control ON/OFF switch and the vehicle ignition switch are both ON.

3. Pressing the LOWER button for 0.75 seconds will engage the FLOAT mode. The control indicator FLOAT light will glow. Cancel the FLOAT mode by momentarily pressing the RAISE button.

Function Time Outs

All control functions, except for LOWER, automatically time out – stop – after a period of time. This is to prevent unnecessary battery drain. The time-out period for the RAISE function is 4.8 seconds, while the angle function is 9.6 seconds.

The control will automatically turn off after being idle for 20 minutes.

Smooth Stop

The control automatically allows the blade to coast to a stop. This results in smoother operation, reduces the shock to the hydraulic system and increases hose and valve life.

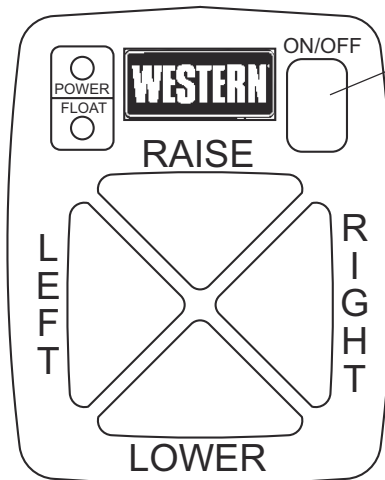

Emergency Stop

Button	Description of Operation
Raise	Press this button to raise the snowplow and to cancel the float mode. NOTE: Snowplow automatically stops raising after 4.8 seconds. To resume raising the snowplow, release the button and press again.
Lower/ Float	Press this button to lower the snowplow. NOTE: After reaching the desired height, release the button. Holding the button down for more than 0.75 seconds activates the float mode, indicated by green FLOAT lamp.
Cancel Float	Cancel the float mode by momentarily pressing the RAISE button, turning control off, or turning vehicle ignition off. Angling left or right momentarily cancels float.
Right	Press this button to angle blade to the right.
Left	Press this button to angle blade to the left.

THEORY OF OPERATION

SNOWPLOW HEADLAMPS

The type of headlamp circuit varies, depending on the make/model/year of vehicle and whether or not it is equipped with Daytime Running Lights (DRLs). The headlamp switching circuit uses two or more relays. When combined with the plug-in headlamp harness, plow light harness and vehicle harness, the relays automatically switch between the vehicle and snowplow headlamps as the harness plugs are connected and disconnected.

Vehicles with Daytime Running Lights (DRLs) require a DRL kit which is an additional fused pink wire used in place of the brown wire.

SNOWPLOW PARK/TURN LAMPS

In an ordinary installation, the snowplow Park/Turn lamps are wired in parallel with the corresponding vehicle circuits. Some installations on trucks with clearance lights require an optional Park/Turn Relay Kit which allows the snowplow park lamps to operate directly off the battery, using the vehicle circuit to power only the relay. In either case, the vehicle and snowplow park and turn lamps will operate simultaneously.

The headlamp wiring schematics and electrical information included in this manual are typical for most 1998 and older vehicles. For 1999 and newer vehicles, refer to the snowplow installation instructions or *Electrical Schematics Guide*.

SNOWPLOW HYDRAULICS

The snowplow hydraulic system performs four blade movement functions. All functions require the vehicle ignition (key) switch to be in the run position and the cab control to be turned on.

The cab control supplies power to the motor relay and the three solenoid cartridge valves in various combinations to direct hydraulic fluid to the snowplow lift and angle cylinders or back to the reservoir.

Raise and angle functions require both the motor and solenoid cartridge valve(s) to activate, while the lower function only requires activation of a solenoid cartridge valve. The motor and valves are deactivated when the cab control button or lever is released. The high amperage motor power circuit is completed through the battery cables when the motor relay is activated. The motor relay and solenoid cartridge valve circuits are low amperage, high side drive, and are completed when the cab control is activated.

Proper operation of the snowplow hydraulic system depends on the vehicle's ability to provide adequate electrical power. Electrical loads from the snowplow, vehicle and accessories can substantially reduce the vehicle system voltage if the charging system cannot meet the electrical demand. A low voltage condition can cause intermittent snowplow operation because the magnetic field produced in the solenoid cartridge valve coils may not be strong enough to shift the valves. Because of many variables, it is impossible to determine the point at which the system voltage is too low to consistently operate the snowplow. This condition can be difficult to diagnose because the coil magnetism can still be detected and no problem exists in the hydraulic system. Do not overlook the fact that an apparent problem with the snowplow can actually be caused by low voltage in the vehicle electrical system. Consult a vehicle repair manual for electrical system specifications.

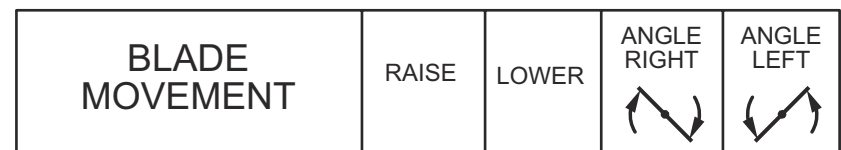















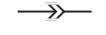

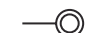





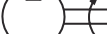
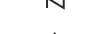

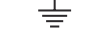

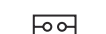

HYDRAULIC AND ELECTRICAL SCHEMATICS

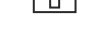
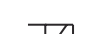
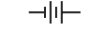
The following section contains hydraulic and electrical schematics to help explain how the hydraulic unit performs the different functions. A schematic is an abstract drawing showing the purpose of each of the components in the system. Each component is represented by a graphical symbol. The hydraulic and electrical legends list and describe each of the symbols used in the schematics for this guide.

The first two schematics show a general overview of the complete hydraulic and electrical systems. The remainder of the schematics have been altered to highlight flow of hydraulic oil and electrical current for each function the hydraulic unit performs or flow of electrical current for the snowplow and vehicle lights.

- Bold lines represent the circuit being activated only.
- Shaded components are either activated or shifted from their normal position.

**NOTE: Left side = Driver side
Right side = Passenger side**

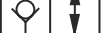
HYDRAULIC LEGEND		ELECTRICAL LEGEND	
	LINE, WORKING (MAIN)		CROSSING WIRE
	LINE, PILOT (FOR CONTROL)		WIRE SPLICE
	LINES JOINING		IN LINE CONNECTOR
	LINES CROSSING		RING TERMINAL
	FLOW, DIRECTION OF HYDRAULIC FLUID		FUSE
	LINE, TO RESERVOIR BELOW FLUID LEVEL		SOLENOID
	HYDRAULIC PUMP FIXED DISPLACEMENT		DIODE
	CYLINDER		CIRCUIT GROUND
	ELECTRIC MOTOR		MOTOR RELAY
	FILTER, STRAINER DIFFUSER		BATTERY
	COMPONENT ENCLOSURE		MOTOR
	SPRING		PARK/TURN LAMP
	SOLENOID, SINGLE WINDING		HEADLAMP
	PILOT OPERATED (P/O) CHECK VALVE		COMPONENT ENCLOSURE
	VALVE, ADJUSTABLE PRESSURE RELIEF		
	VALVE, FLOW CONTROL, ADJUSTABLE-NON-COMPENSATED		
	VALVE, TWO POSITION TWO CONNECTION (TWO WAY) S1		
	VALVE, TWO POSITION THREE CONNECTION (THREE-WAY) S2		
	VALVE, TWO POSITION FOUR CONNECTION (FOUR-WAY) S3		
	CHECK VALVE		

Wire Color Code				Abbreviations					
BLK	Black	BRN/GRN	Brown w/ Green	LTBLU	Light Blue	PUR	Purple	DRL	Daytime Running Lights
BLK/ORN	Black w/ Orange	BRN/RED	Brown w/ Red	LTGRN	Light Green	RED	Red	MTR RLY	Motor Relay
BLK/RED	Black w/ Red	DKBLU	Dark Blue	LTBLU/ORN	Light Blue w/ Orange	TAN	Tan	P/T SIG	Park/Turn Signal
BLK/WHT	Black w/ White	DKBLU/ORN	Dark Blue w/ Orange	LTBLU/WHT	Light Blue w/ White	VIO	Violet		
BLU	Blue	DKBLU/WHT	Dark Blue w/ White	ORN	Orange	WHT	White		
BLU/ORN	Blue w/ Orange	GRN	Green	ORN/BLK	Orange w/ Black	WHT/YEL	White w/ Yellow		
BRN	Brown	GRY	Gray	PNK	Pink	YEL	Yellow		

ELECTRICAL SCHEMATIC – 9-PIN HARNESS–TYPICAL

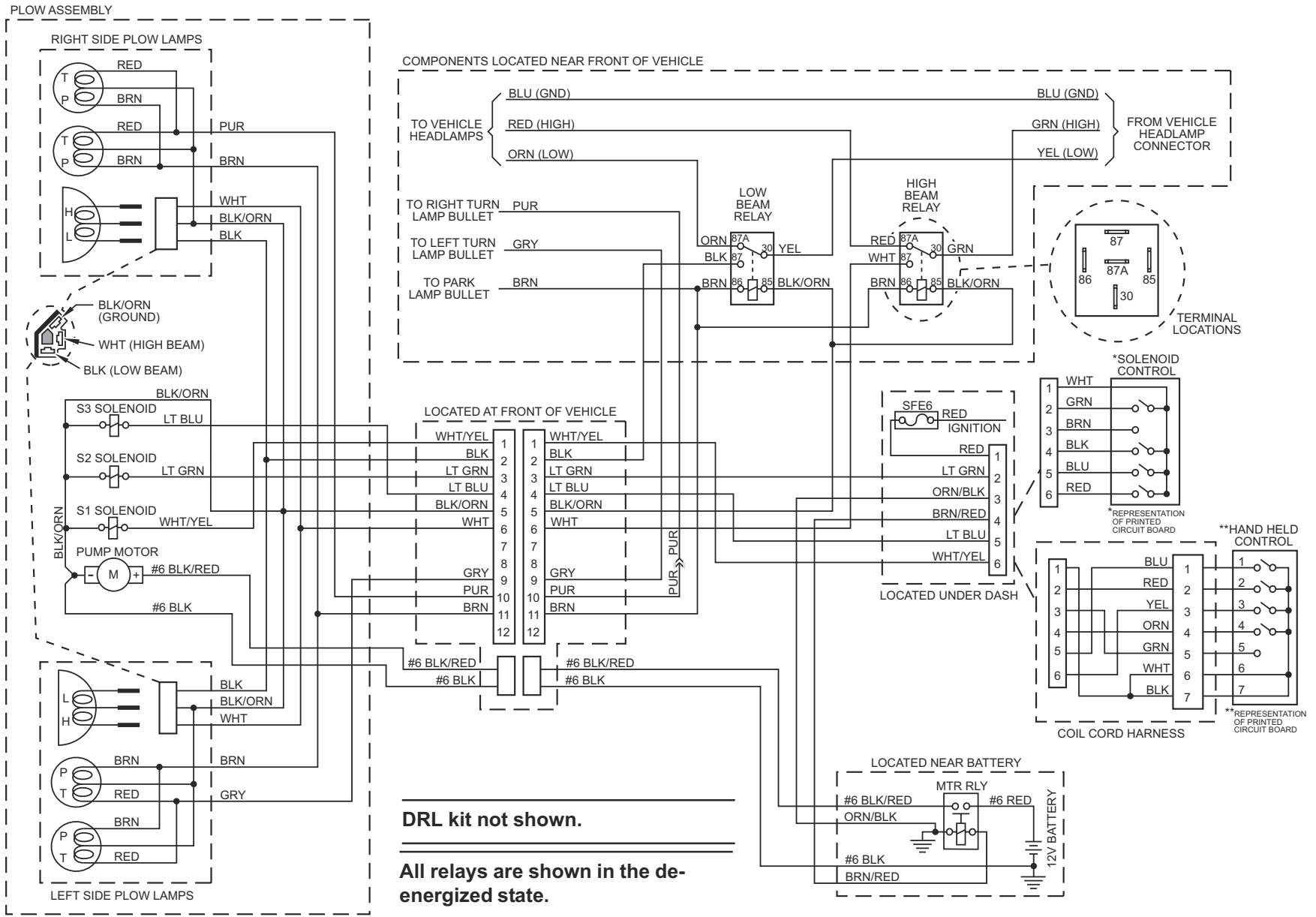

ELECTRICAL SCHEMATIC – 12-PIN HARNESS (TYPICAL)

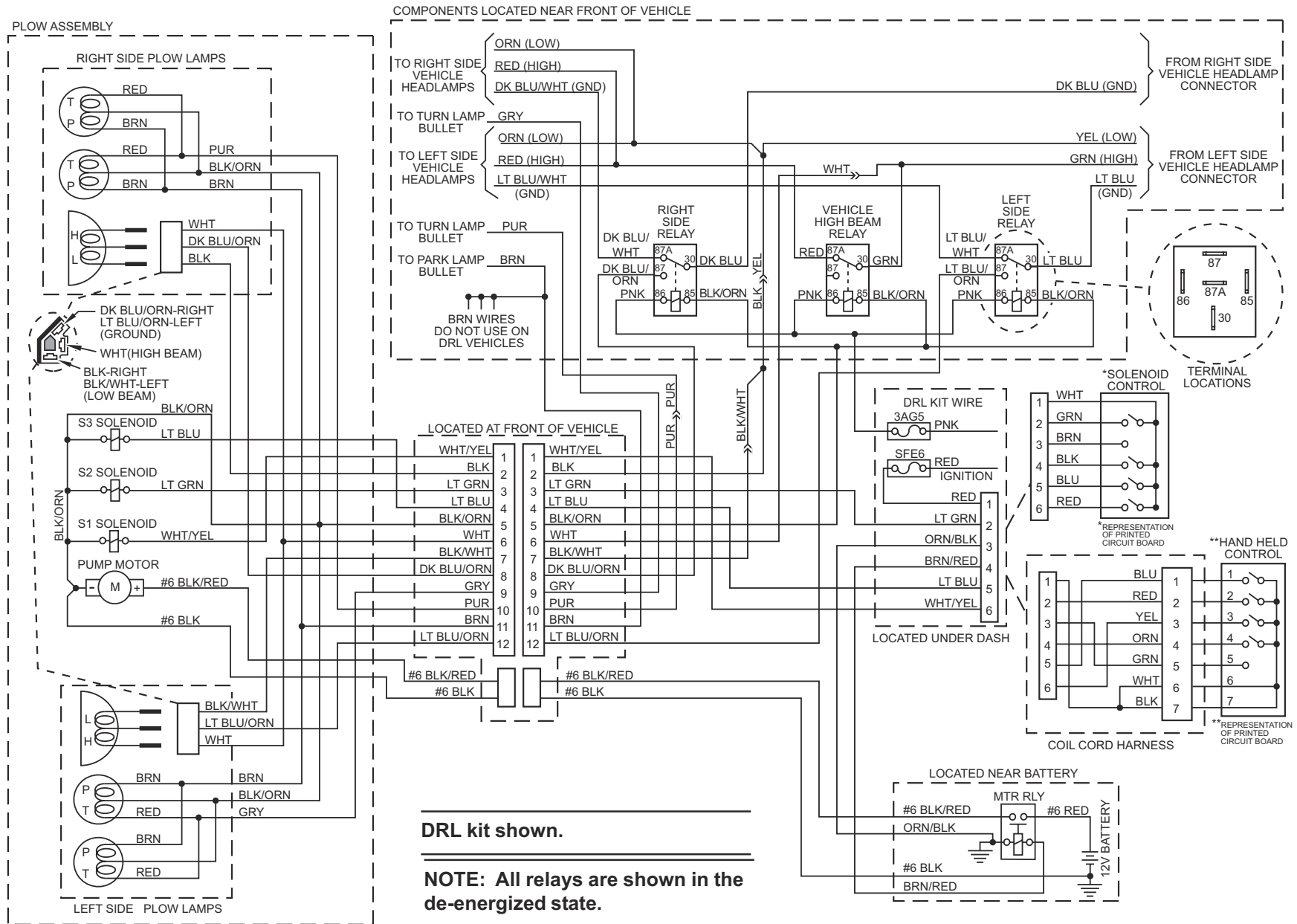

HYDRAULIC SCHEMATIC

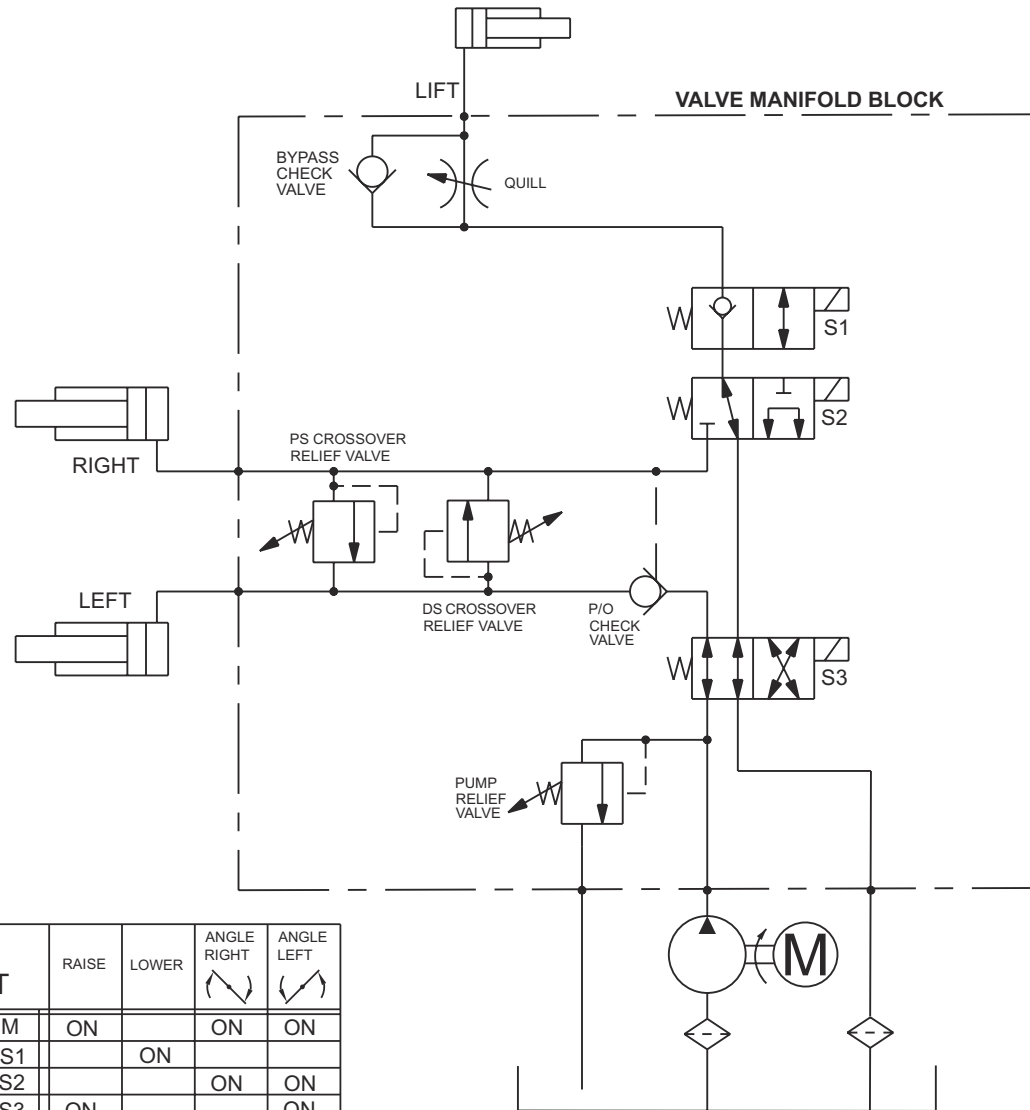

RAISE – ELECTRICAL

Blade Movement: Raise

Control: Raise

System Response:

1) By moving control lever or pressing the controller button, the circuit board within the cab control supplies power for the electrical circuits.

2) Electrical current flows through the motor relay, activating the pump motor, and solenoid cartridge valve S3, shifting the spool.

3) Hydraulic oil from the pump flows through the solenoid cartridge valves S3 & S2 and the internal check valve in solenoid cartridge valve S1, and into the lift cylinder causing it to extend.

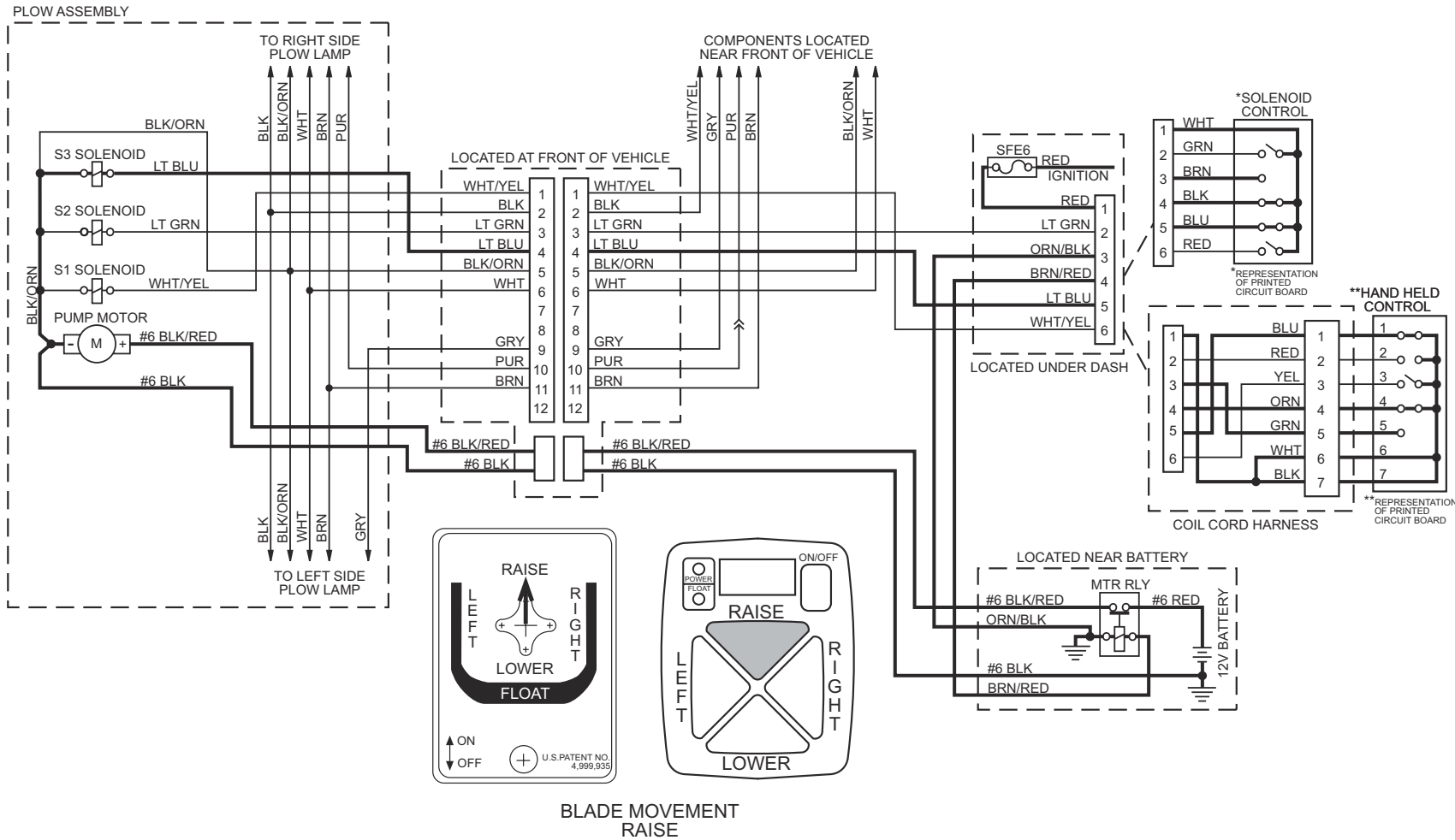

RAISE – HYDRAULIC

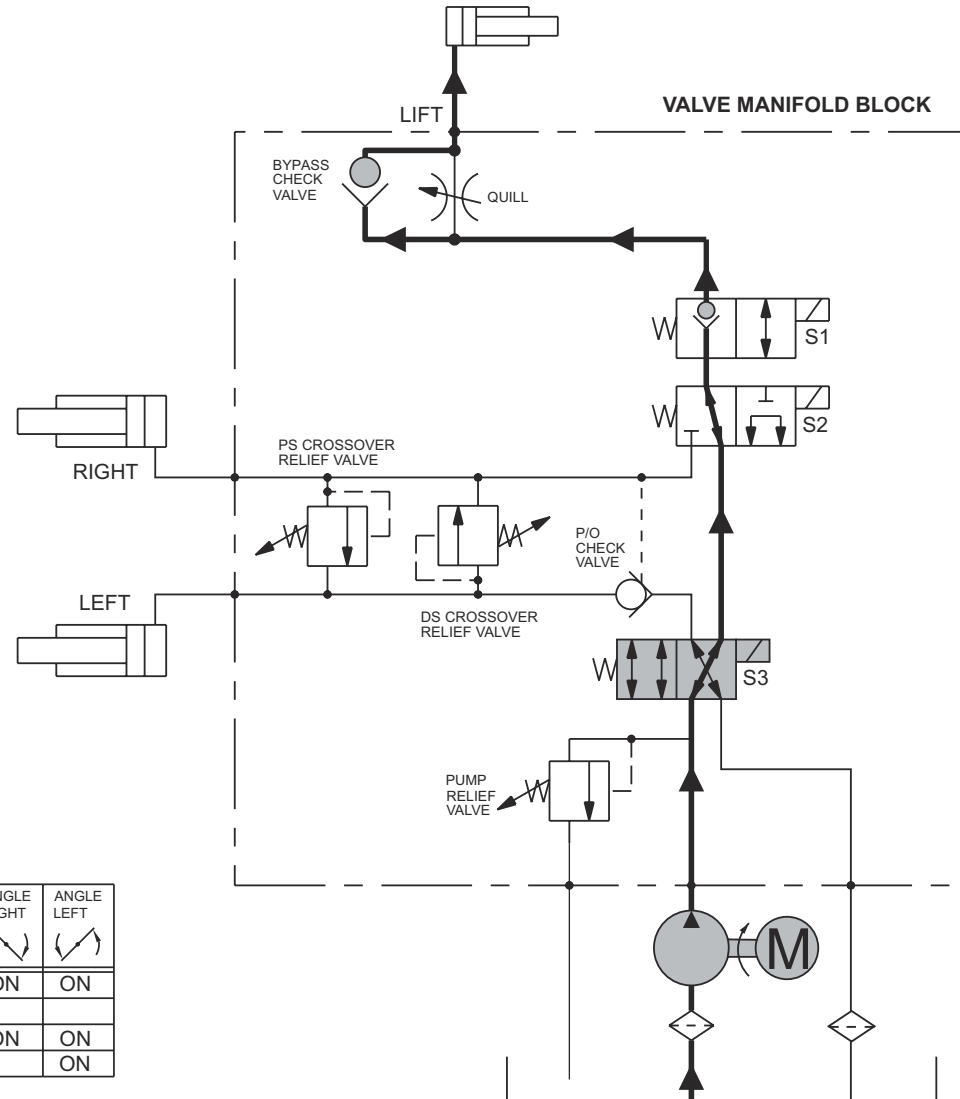

BLADE MOVEMENT		RAISE	LOWER	ANGLE RIGHT	ANGLE LEFT
MOTOR	M	ON		ON	ON
SV08-2004	S1		ON		
SV08-31	S2			ON	ON
SV08-40	S3	ON			ON

LOWER – ELECTRICAL

Blade Movement: Lower / Float

Control: Lower

System Response:

1) By moving control lever or pressing the controller button,

the circuit board within the cab control supplies power for the electrical circuit.

2) Electrical current flows through solenoid cartridge valve S1, shifting the spool.

3) The weight of the plow forces the lift cylinder to retract. The retracting lift cylinder pushes the hydraulic oil through solenoid cartridge valves S1 & S2 & S3, and back to the reservoir.

NOTE: CabCommand hand-held control only – while in FLOAT, angling right or left will temporarily cancel float (turn off solenoid cartridge valve S1) until the angle button is released.

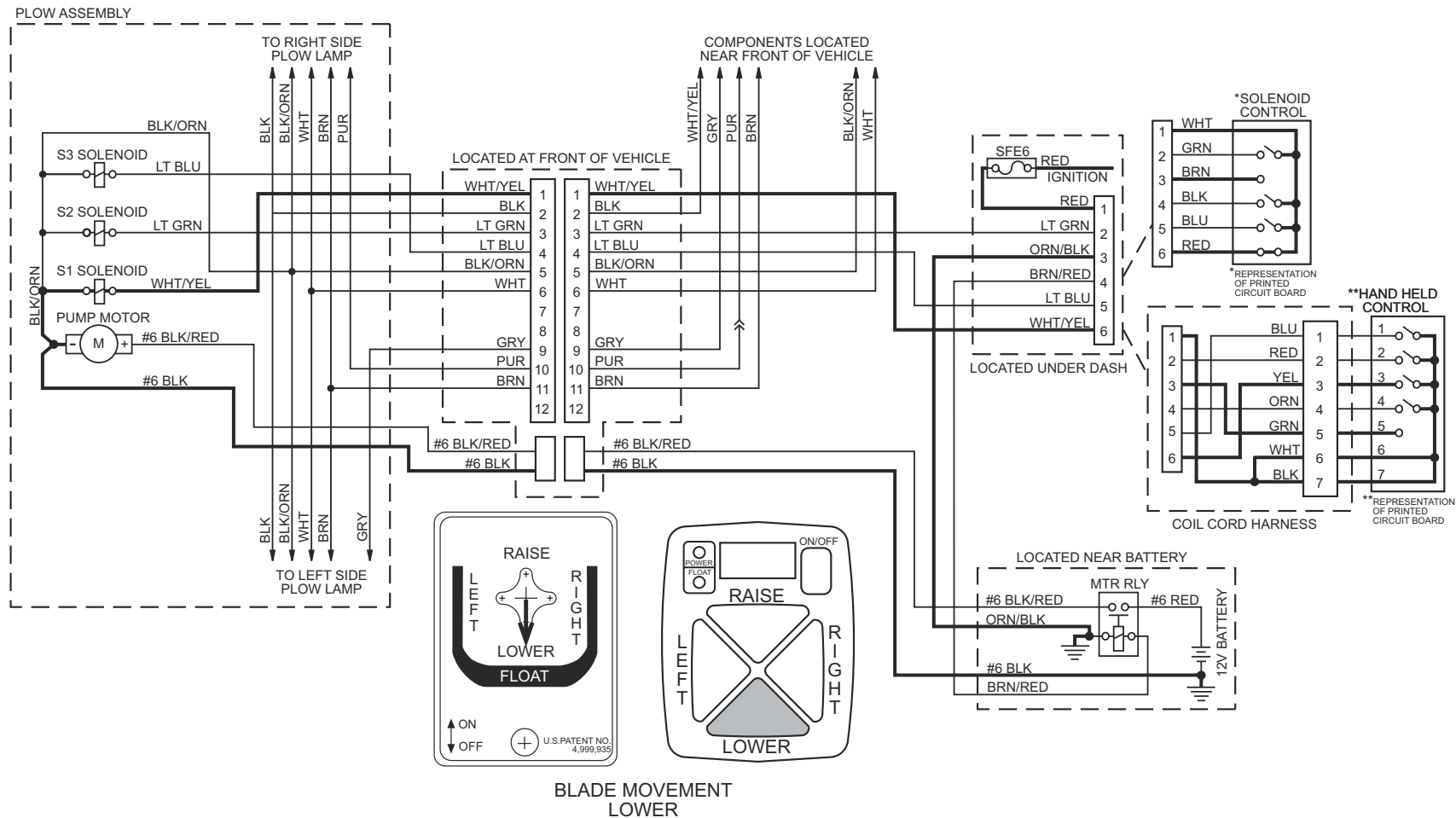

LOWER – HYDRAULIC

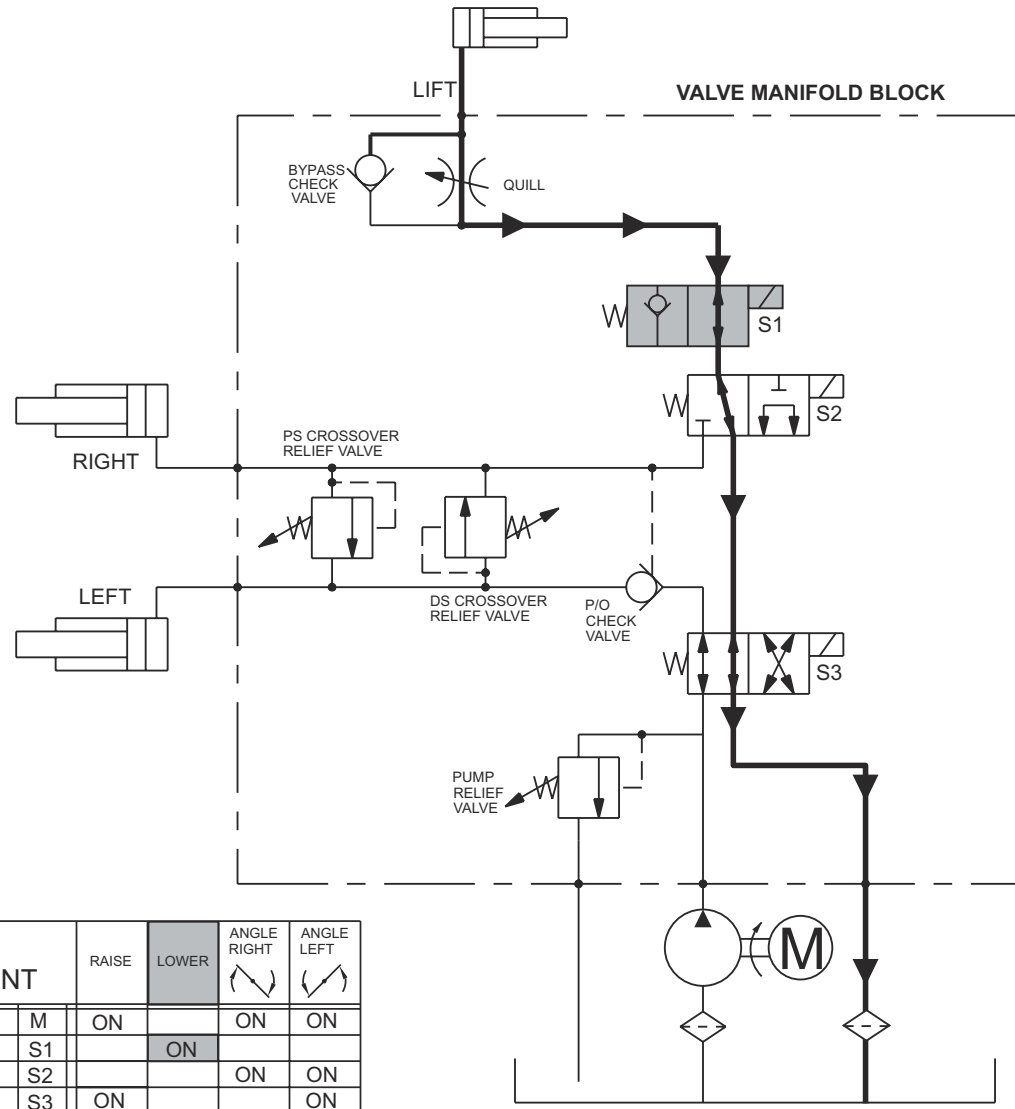

ANGLE RIGHT – ELECTRICAL

Blade Movement: Angle Right

Control: Right

System Response:

1) By moving control lever or pressing the controller button, the circuit board within the cab control

supplies power for the electrical circuit.

2) Electrical current flows through the motor relay, activating the pump motor, and solenoid cartridge valve S2, shifting its spool.

3) Hydraulic oil from the pump flows through the solenoid cartridge valve S3 and the poppet check valve, and into the base end of the left cylinder, causing it to extend.

4) The retracting right cylinder pushes the hydraulic oil out of its base end, through solenoid cartridge valves S2 & S3 back to the reservoir.

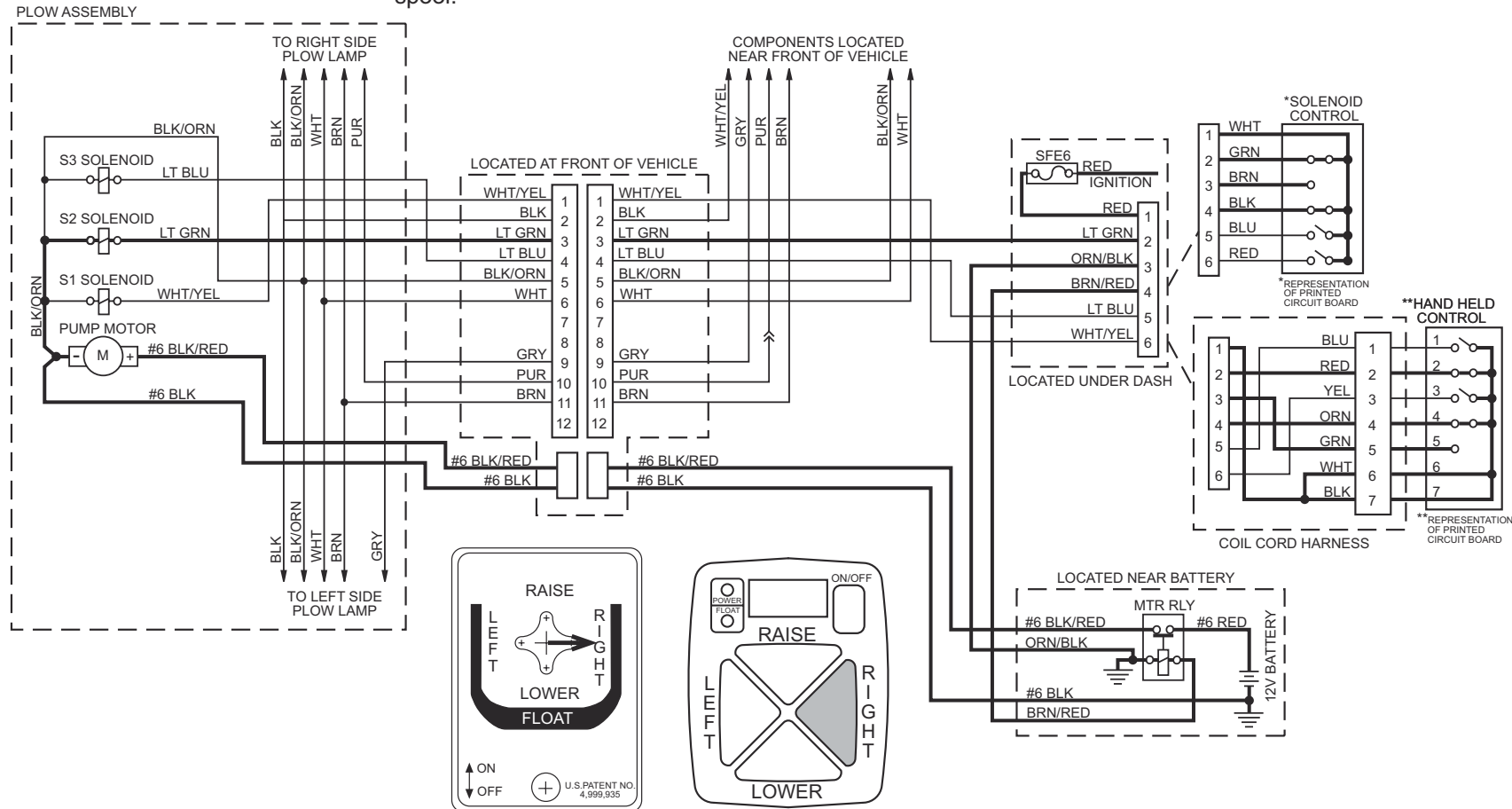

BLADE MOVEMENT
ANGLE RIGHT

ANGLE RIGHT – HYDRAULIC

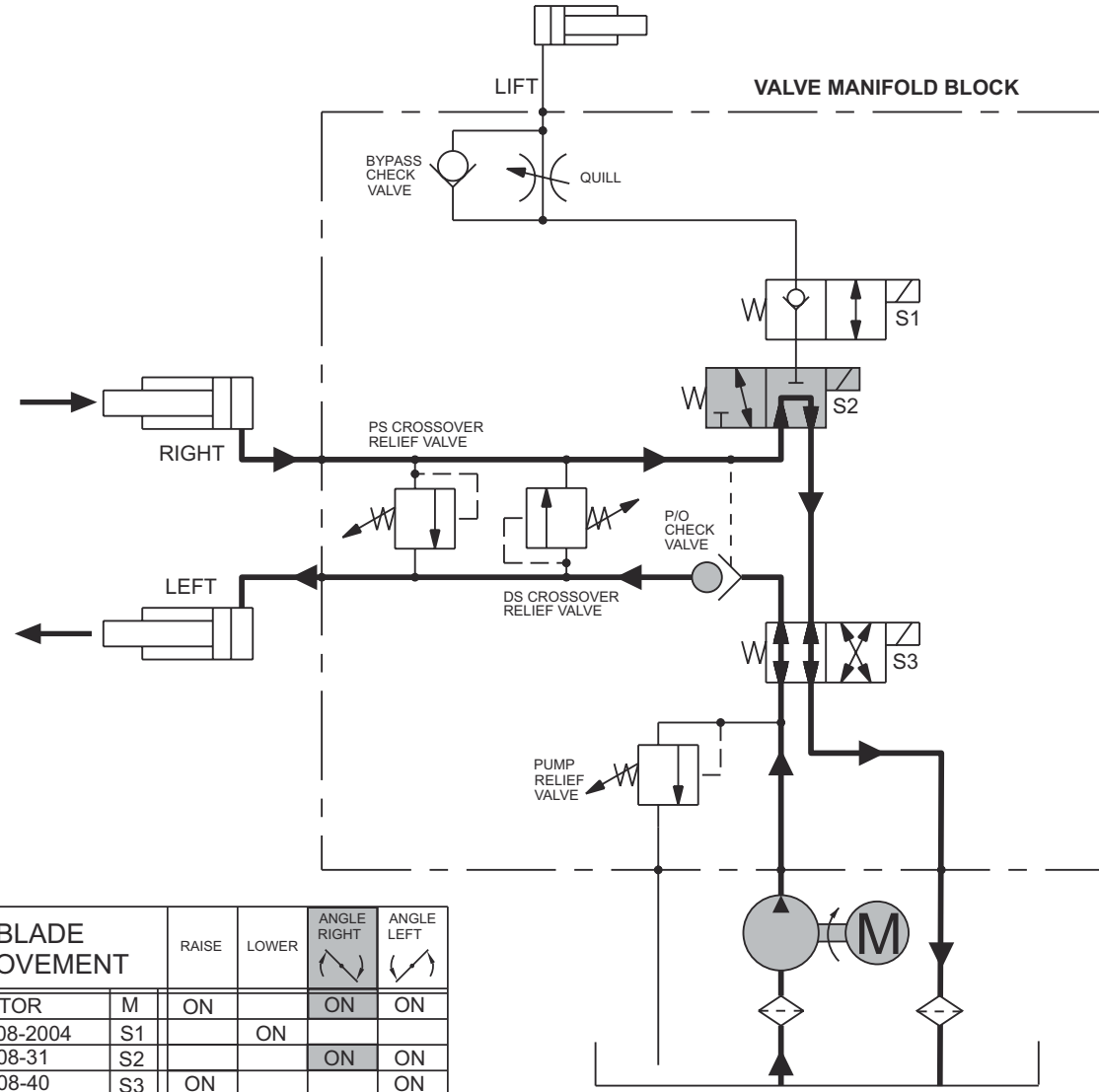

ANGLE LEFT – ELECTRICAL

Blade Movement: Angle Left

Control: Left

System Response:

- 1) By moving control lever or pressing the controller button, the circuit board within the cab control

supplies power for the electrical circuit.

- 2) Electrical current flows through the motor relay, activating the pump motor, and solenoid cartridge valves S2 & S3, shifting both spools.

- 3) Hydraulic oil from the pump flows through the solenoid cartridge valves S3 & S2, and into the base end of the right cylinder, causing it to extend.

- 4) Pressure within the hydraulic circuit shifts the spool, opening the poppet check valve.

- 5) The retracting left cylinder pushes the hydraulic oil out of its base end, through the open poppet check valve and solenoid cartridge valve S3 and back to the reservoir.

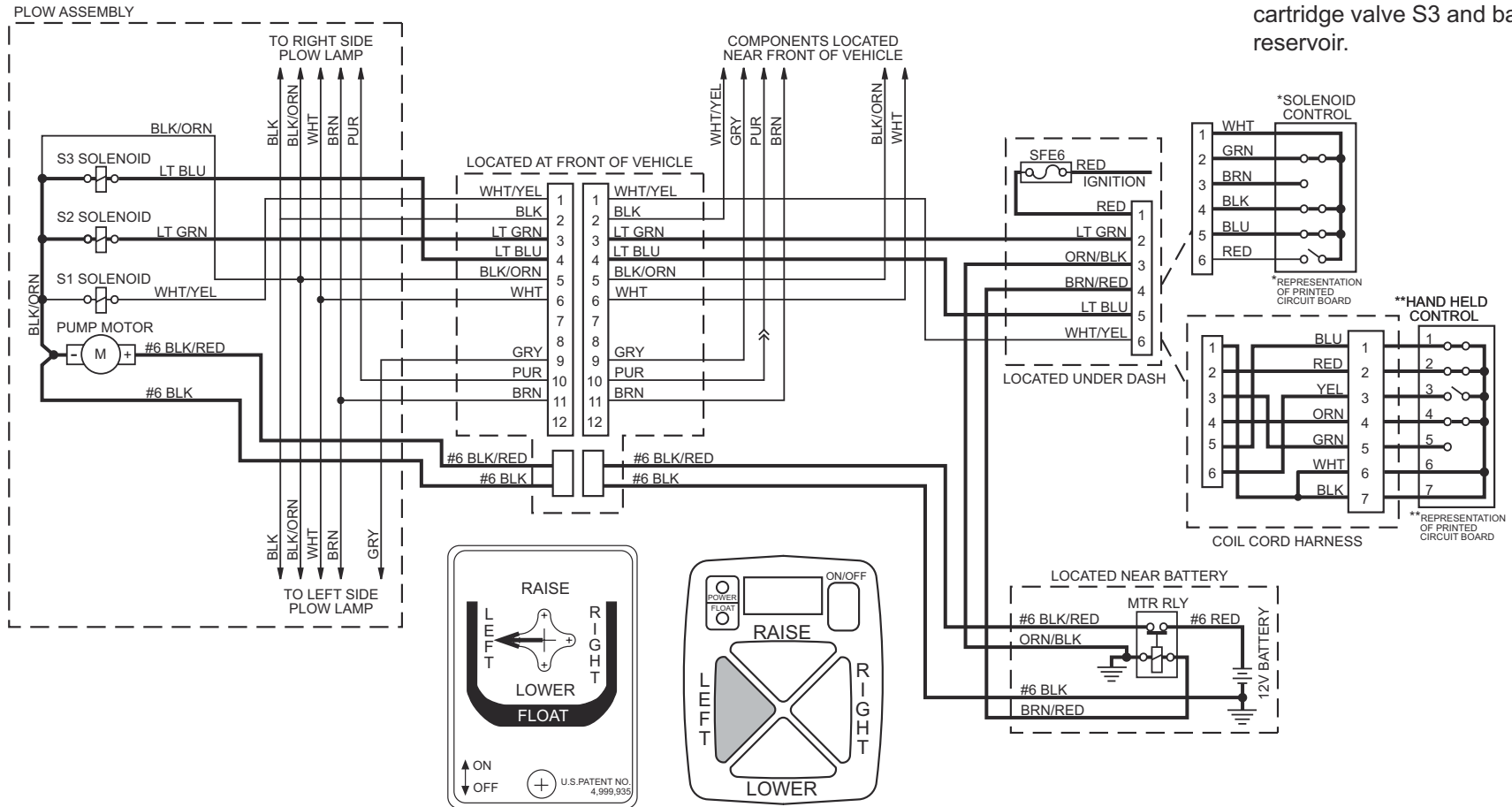

BLADE MOVEMENT
ANGLE LEFT

ANGLE LEFT – HYDRAULIC

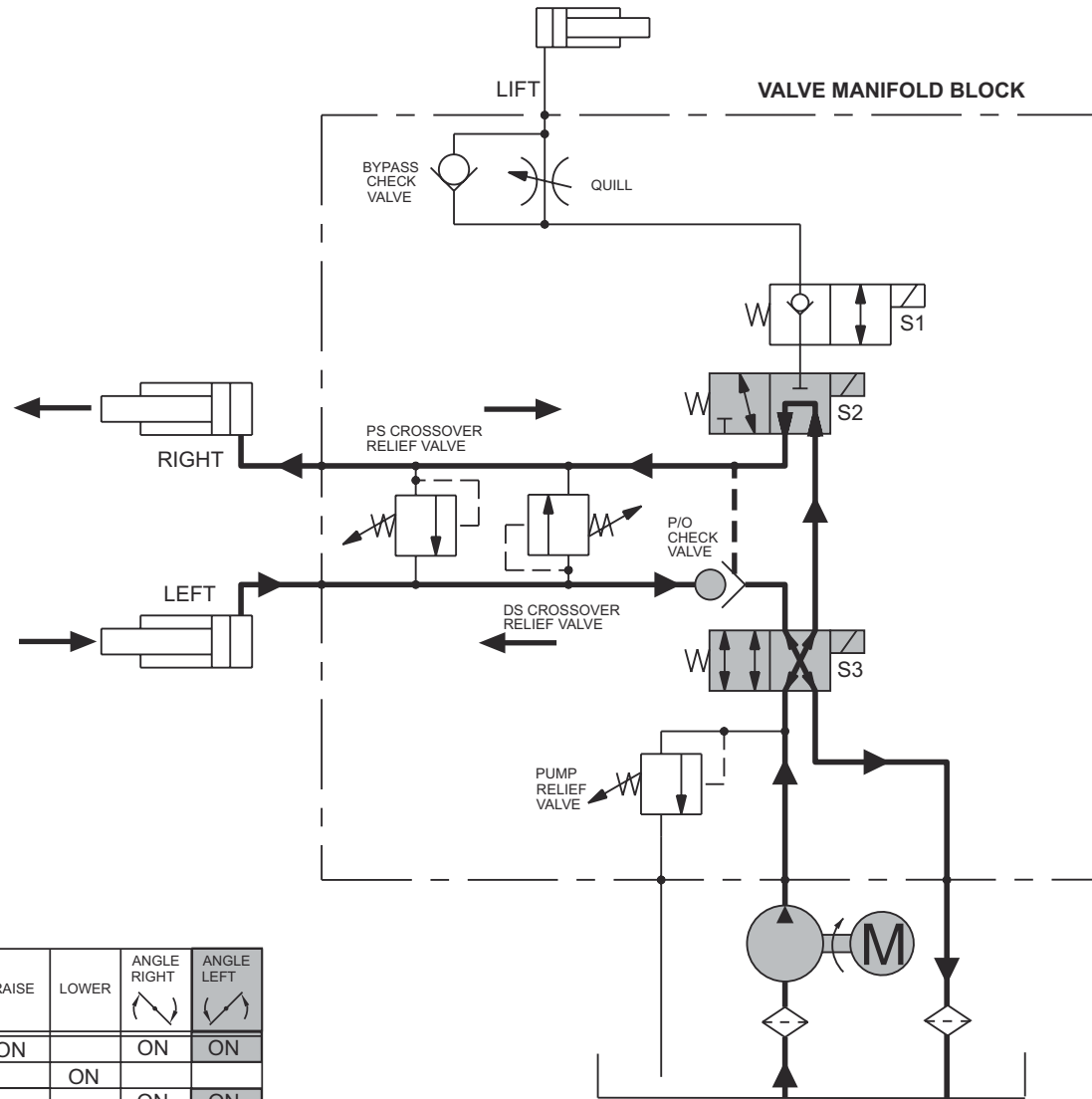

BLADE MOVEMENT		RAISE	LOWER	ANGLE RIGHT	ANGLE LEFT
MOTOR	M	ON		ON	ON
SV08-2004	S1		ON		
SV08-31	S2			ON	ON
SV08-40	S3	ON			ON

HOLD IN RAISED POSITION – HYDRAULIC

Blade Movement: Hold in Raised Position

Control: None

System Response:

- 1) Hydraulic oil is trapped in the lift cylinder by the internal check valve in solenoid cartridge valve S1.

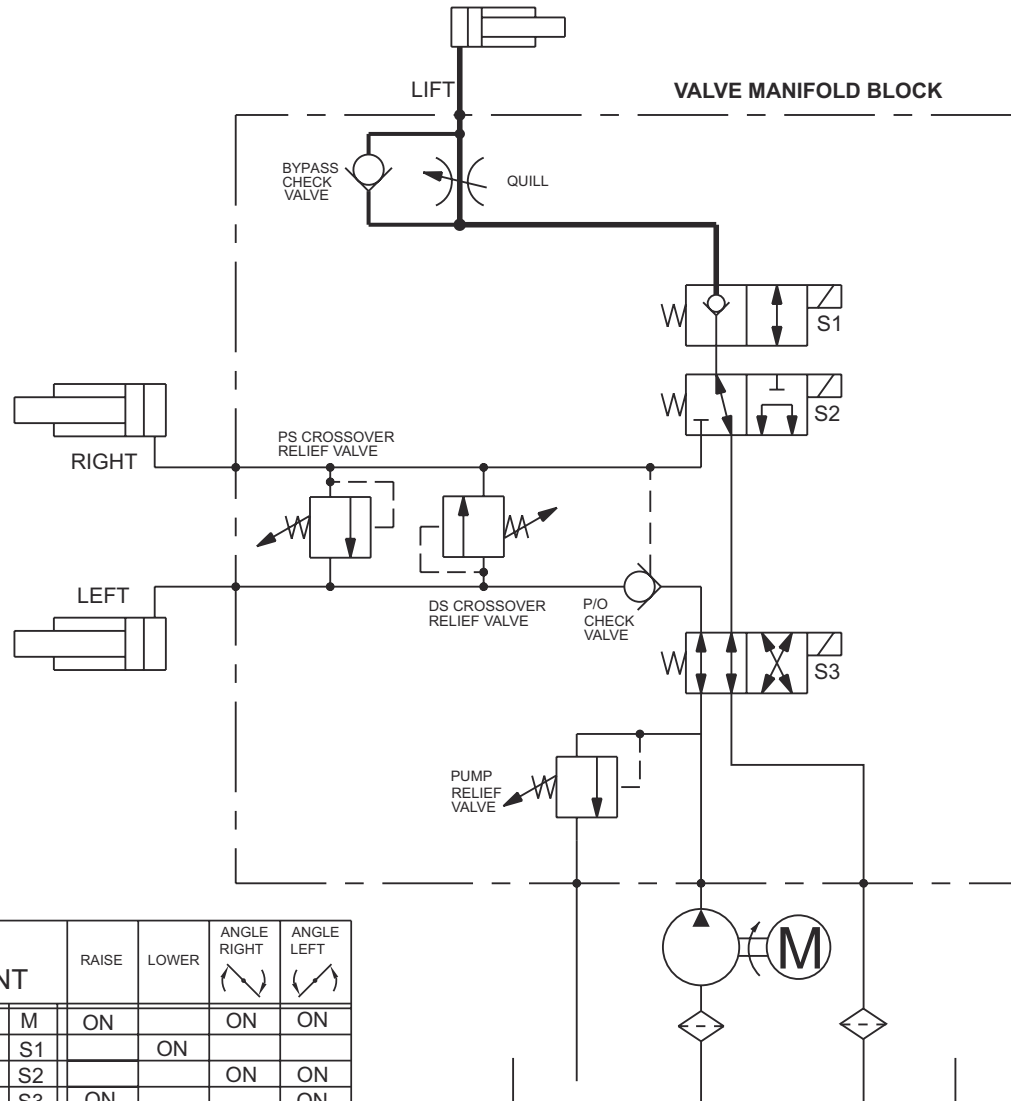

BLADE MOVEMENT		RAISE	LOWER	ANGLE RIGHT	ANGLE LEFT
MOTOR	M	ON		ON	ON
SV08-2004	S1		ON		
SV08-31	S2			ON	ON
SV08-40	S3	ON			ON

STRIKING AN OBJECT WHILE PLOWING – LEFT HYDRAULIC CYLINDER RETRACTS

Blade Movement: Striking an Object While Plowing

Control: None

System Response:

- 1) Hydraulic oil is trapped in the base end of the cylinders by the relief valves, the poppet check valve and solenoid cartridge valve S2.
- 2) When the plow contacts an object, the force of the impact increases the hydraulic pressure in the base end of the cylinder. When the pressure exceeds the relief valve pressure setting, the relief valve opens allowing oil flow to the base of the opposite cylinder.

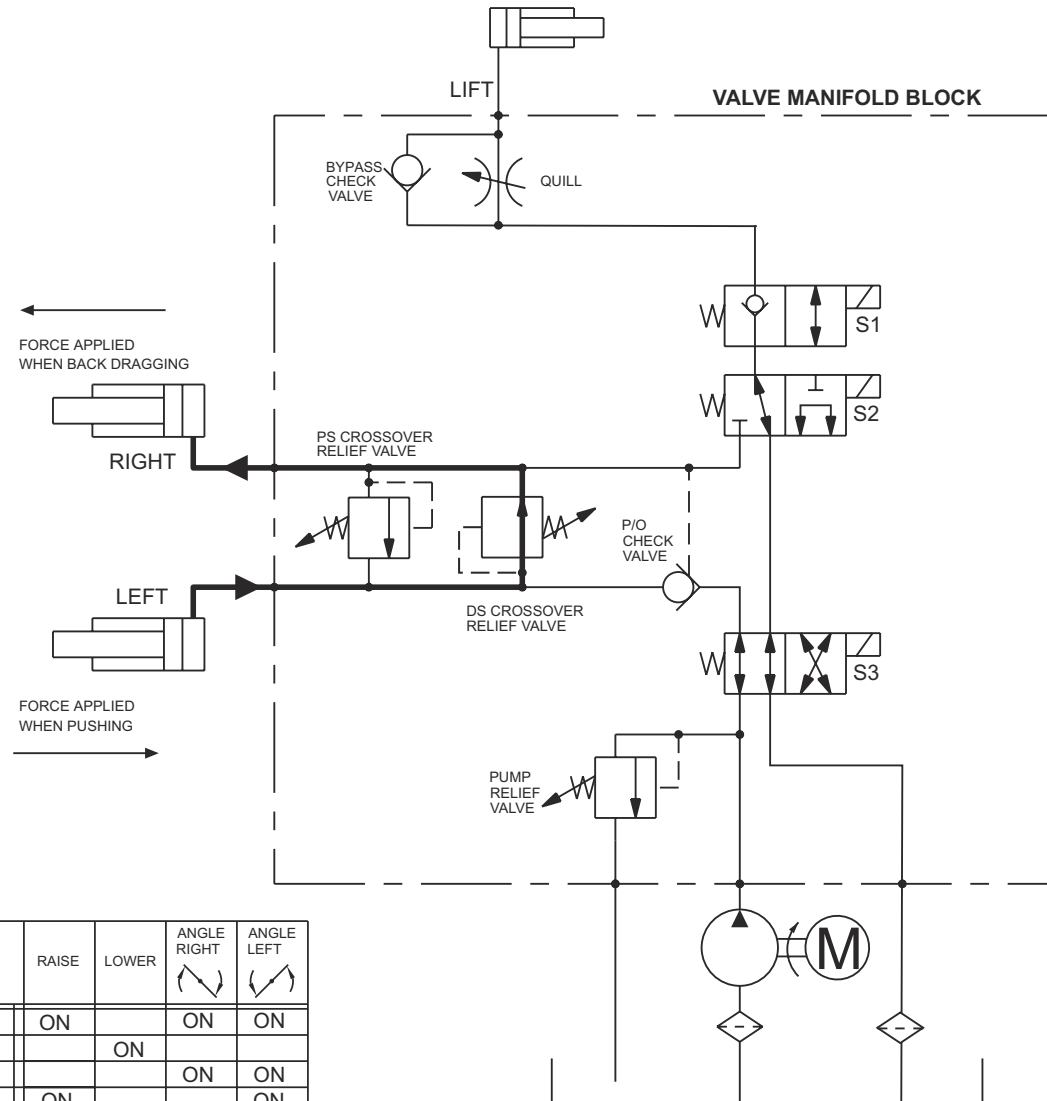

BLADE MOVEMENT		RAISE	LOWER	ANGLE RIGHT	ANGLE LEFT
MOTOR	M	ON		ON	ON
SV08-2004	S1		ON		
SV08-31	S2			ON	ON
SV08-40	S3	ON			ON

STRIKING AN OBJECT WHILE PLOWING – RIGHT HYDRAULIC CYLINDER RETRACTS

Blade Movement: Striking an Object While Plowing

Control: None

System Response:

- 1) Hydraulic oil is trapped in the base end of the cylinders by the relief valves, the poppet check valve and solenoid cartridge valve S2.
- 2) When the plow contacts an object, the force of the impact increases the hydraulic pressure in the base end of the cylinder. When the pressure exceeds the relief valve pressure setting, the relief valve opens allowing oil to flow to the base of the opposite cylinder.

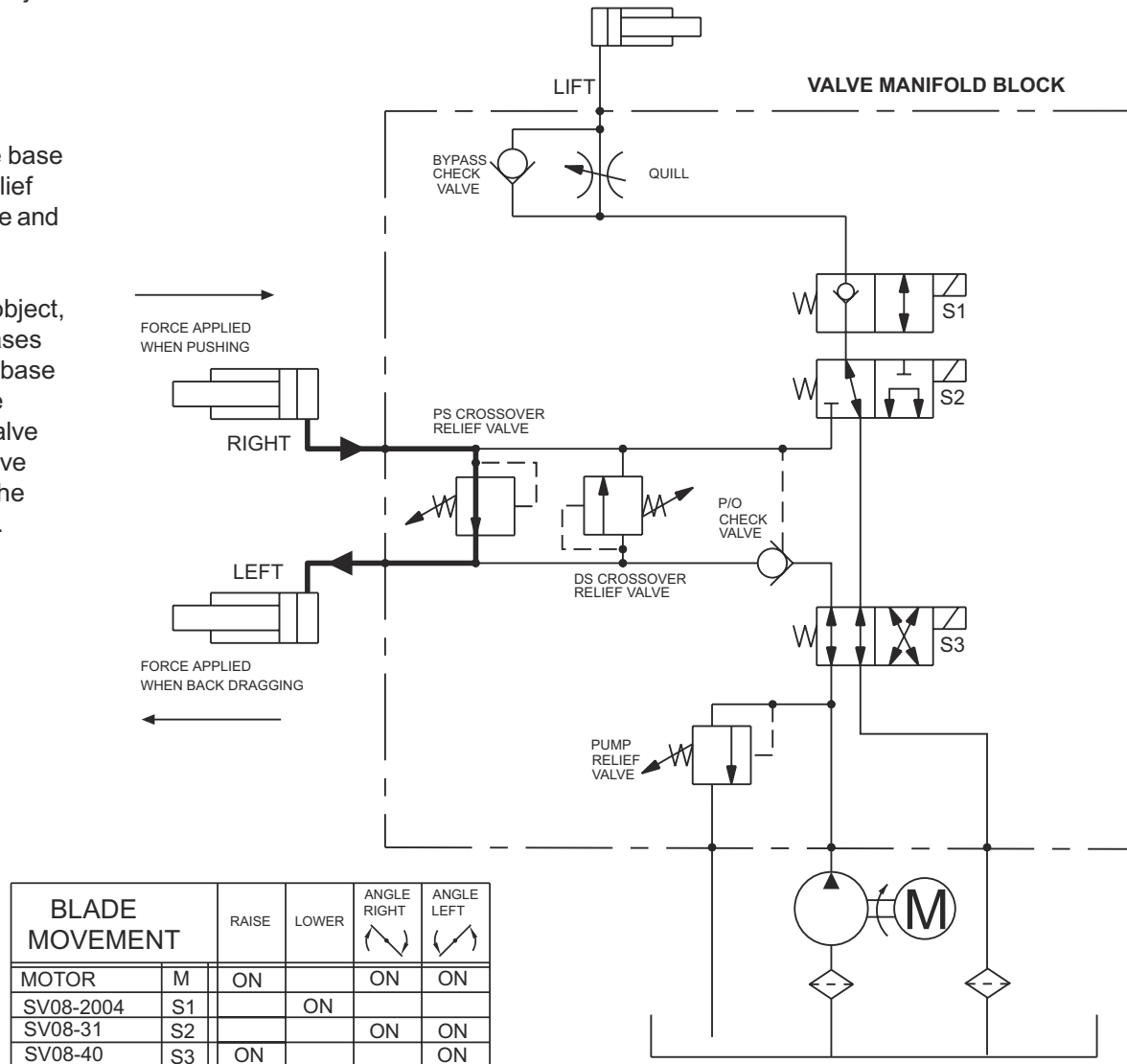

HEADLAMPS – PLOW NOT CONNECTED – 9-PIN (TYPICAL)

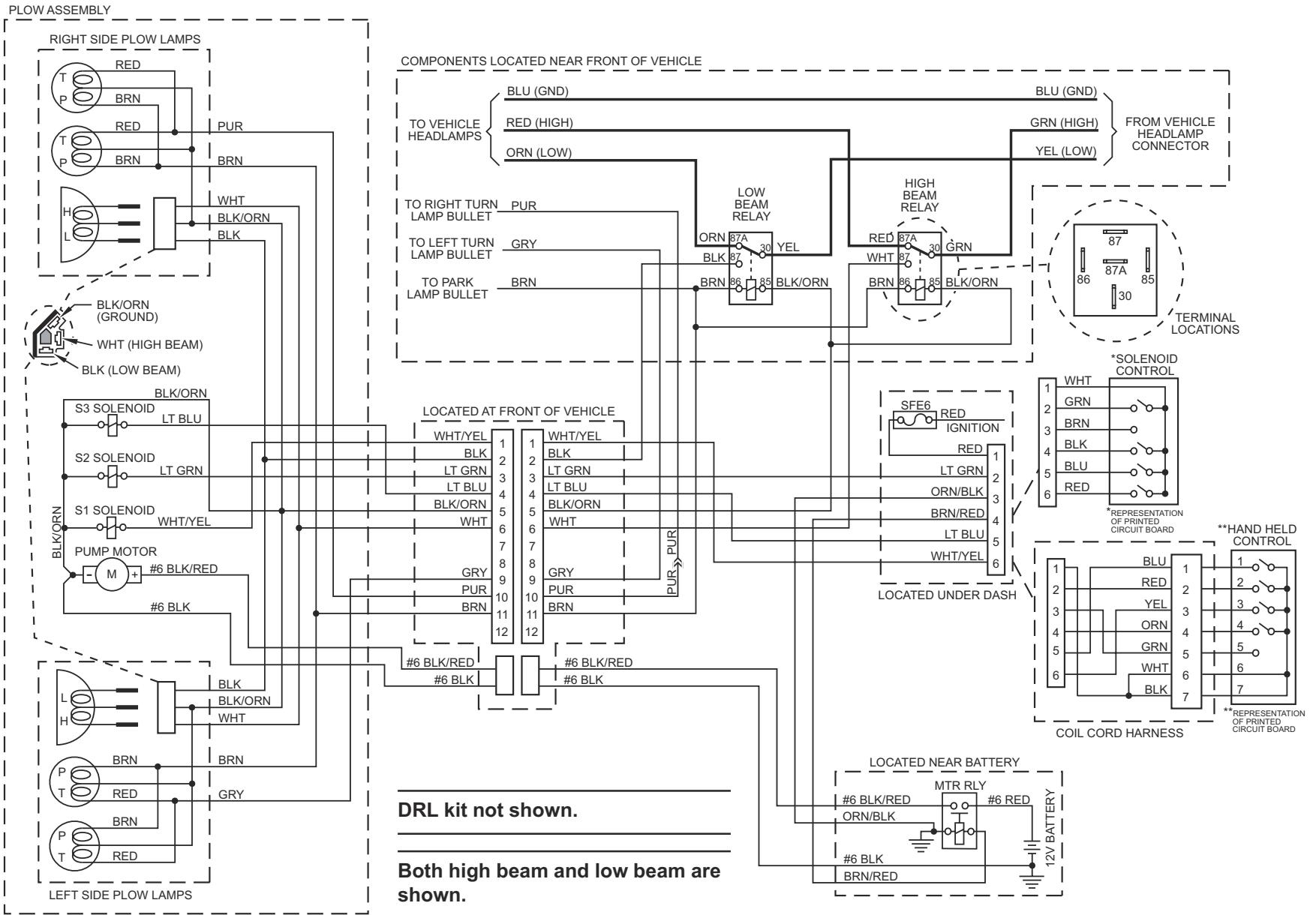

HEADLAMPS – PLOW NOT CONNECTED – 12-PIN (TYPICAL)

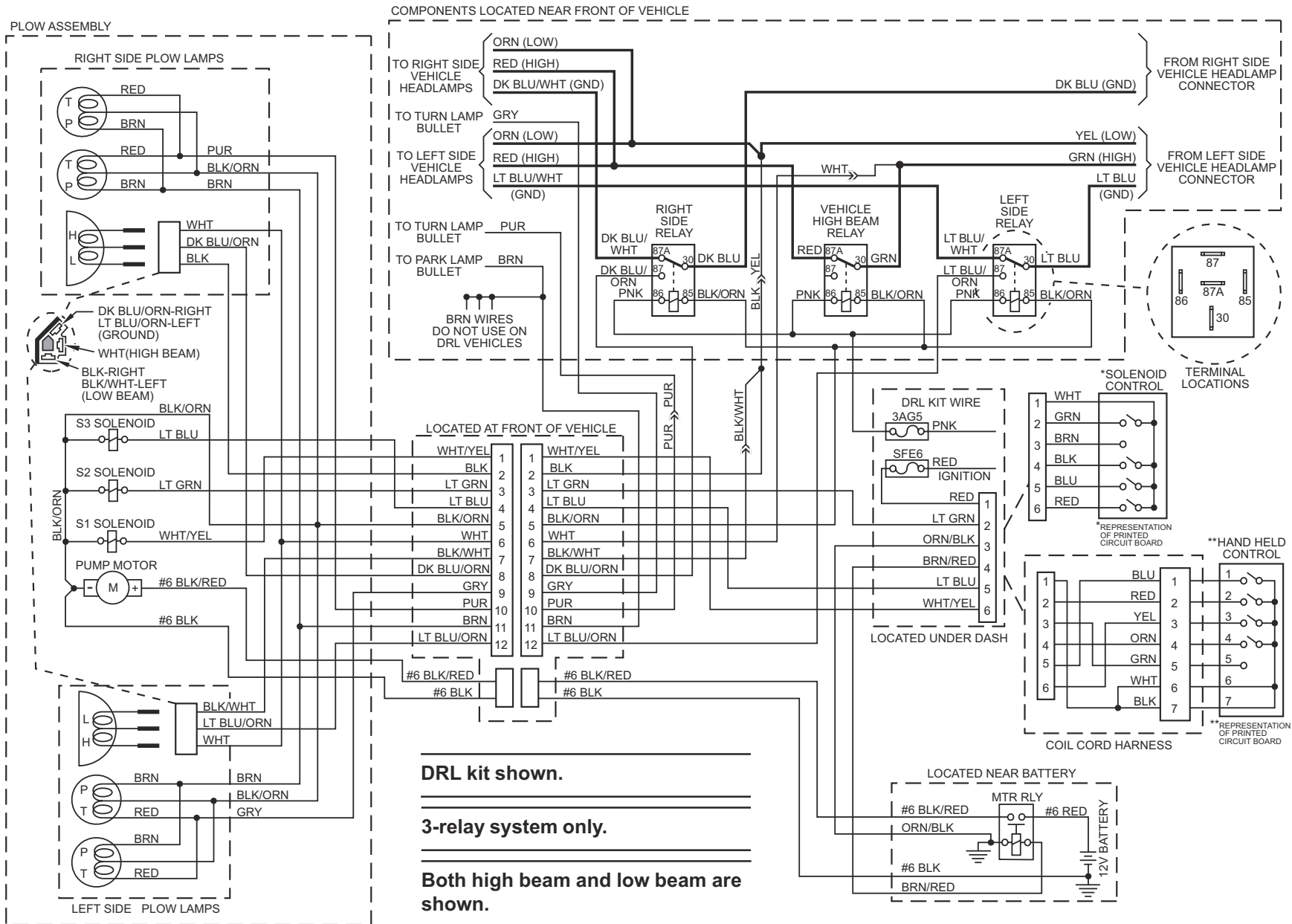

HIGH BEAM HEADLAMPS WITH PLOW CONNECTED TO VEHICLE – 9-PIN (TYPICAL)

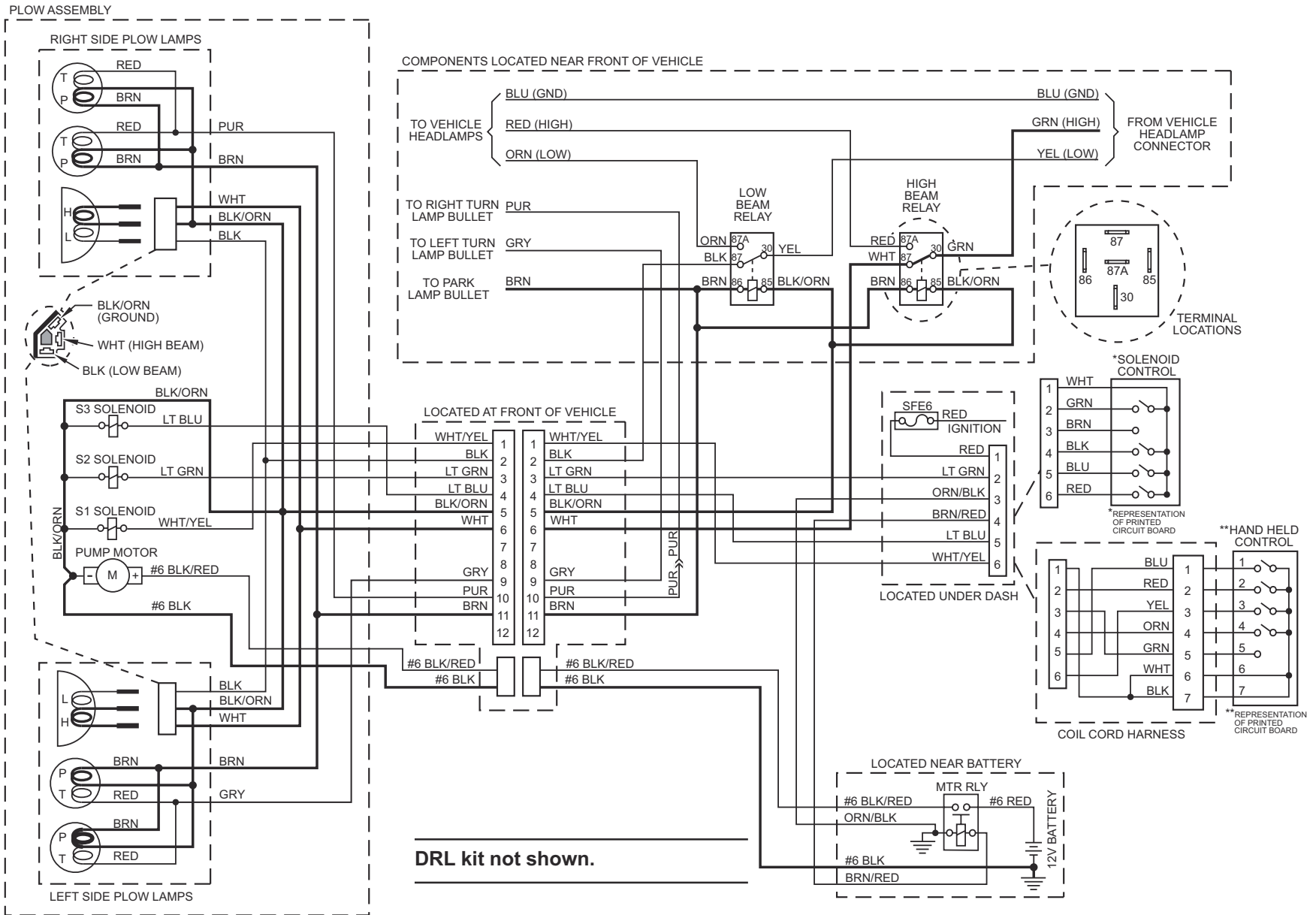

HIGH BEAM HEADLAMPS WITH PLOW CONNECTED TO VEHICLE – 12-PIN (TYPICAL)

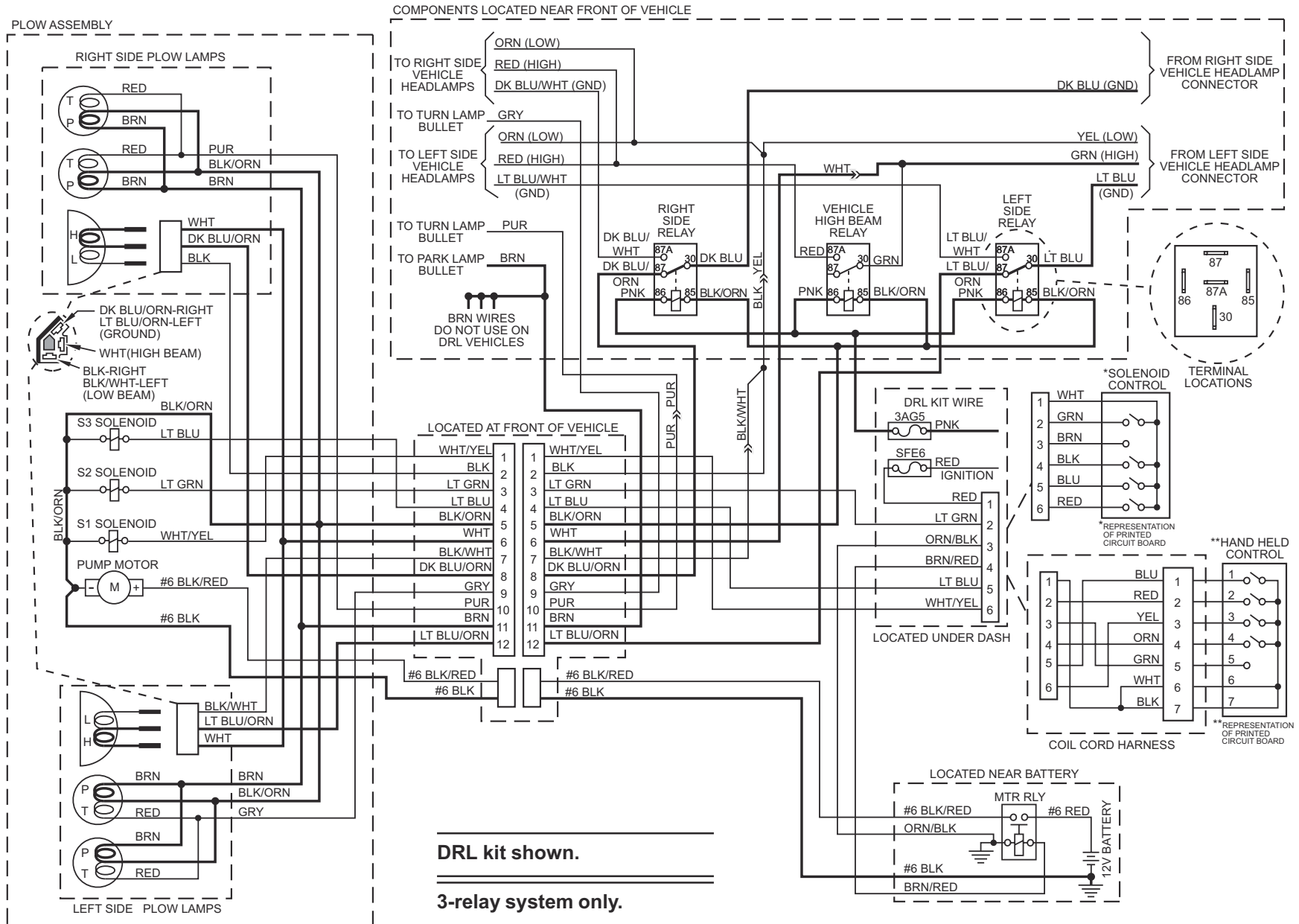

LOW BEAM HEADLAMPS WITH PLOW CONNECTED TO VEHICLE – 9-PIN (TYPICAL)

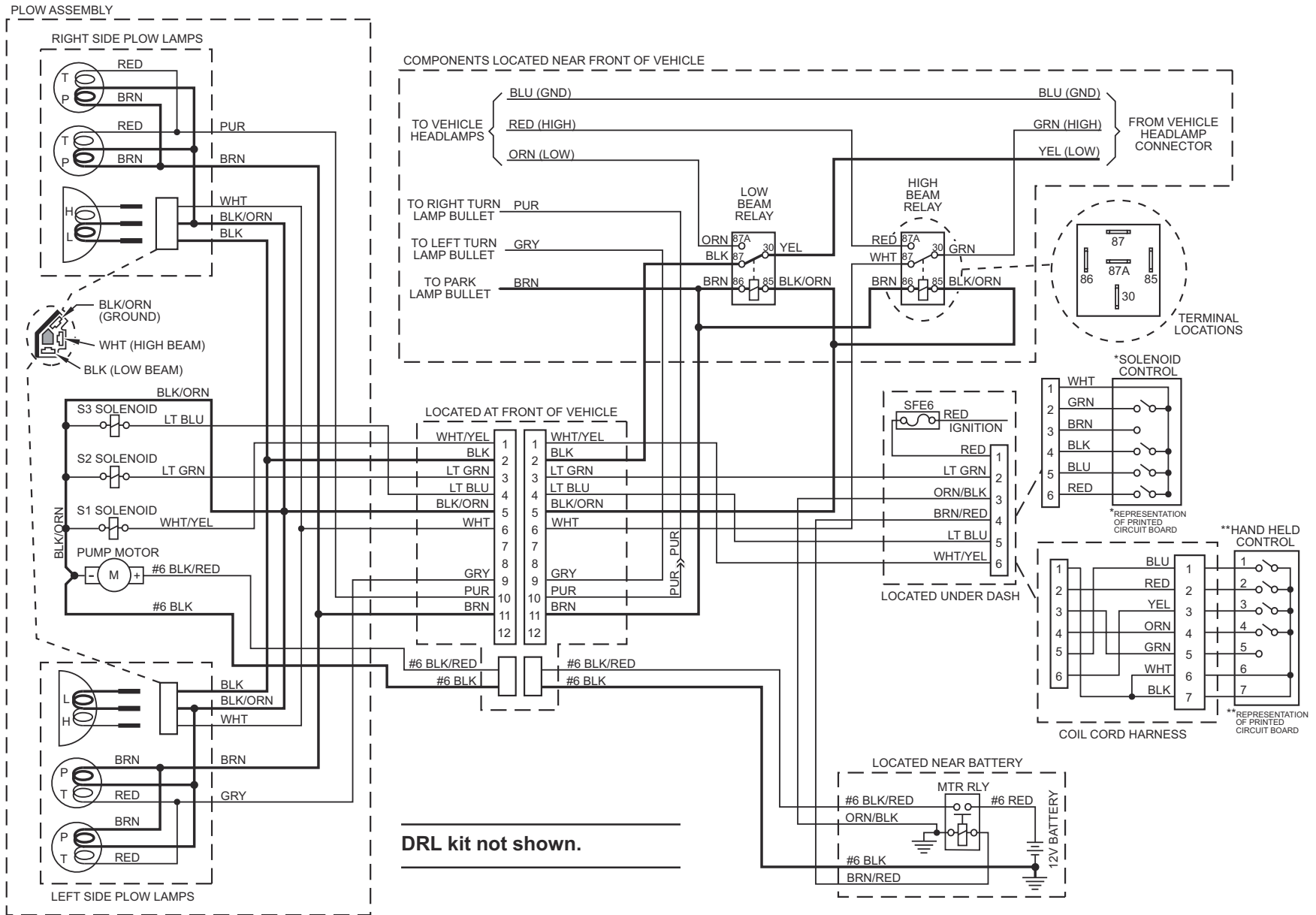

LOW BEAM HEADLAMPS WITH PLOW CONNECTED TO VEHICLE – 12 (TYPICAL)

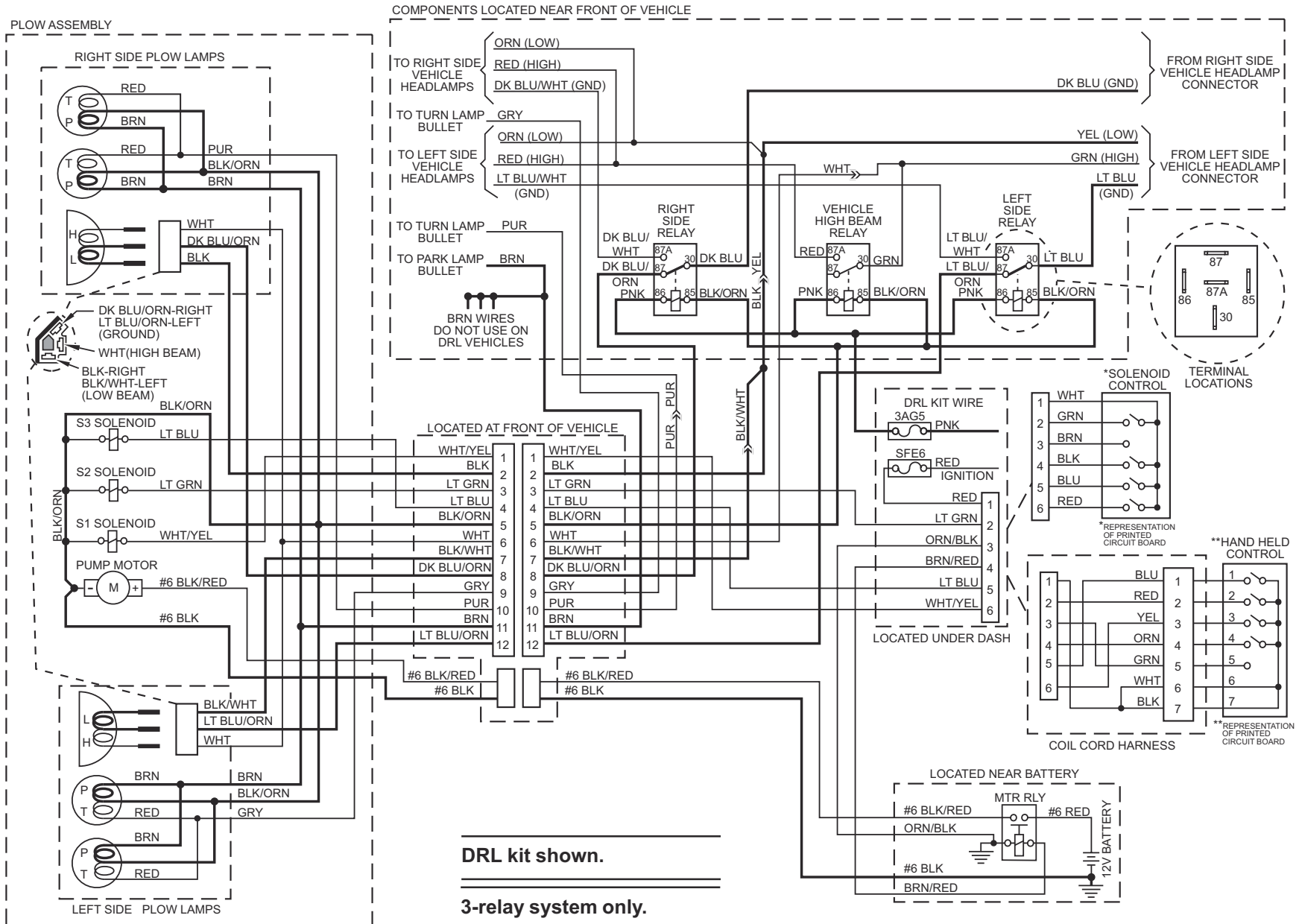

TROUBLESHOOTING GUIDE

Troubleshooting Guide Contents

General Diagnostic Table	39	Headlamp Test Diagram – 9-Pin	58
Hydraulic Rams	42	Vehicle Headlamp Test – 9-Pin	59
Motor Test	44	Plow Headlamp Test – 9-Pin	60
Motor and Motor Relay Test		Plow Park/Turn Lamp Test –	
Diagram	45	9- or 12-Pin	61
Motor Relay Test	46	Optional Park/Turn Relay Kit Test ..	62
Vehicle Harness Test –		Optional Park/Turn Relay Kit	
Motor Relay	47	Schematics	63
Control Test	48	Vehicle Headlamp Test – 12-Pin	64
Pump Pressure Test	50	Plow Headlamp Test – 12-Pin	66
Cartridge Coil Activation Test	52	Headlamp Test Diagram – 12-Pin ..	68
Vehicle Harness Test –			
Cartridge Coils	53		
Hydraulic System Test	54		
Crossover Relief Valve Inspection			
and Adjustment	55		
Poppet Valve Inspection	56		
Individual Solenoid Coil Test	57		
Solenoid Cartridge Valve			
Inspection	57		

Introduction

This guide consists of a series of tables, diagrams, flow charts and other information. When used properly it will assist the mechanic in identifying and repairing malfunctioning system components. Western Products highly recommends the use of the UniMount®/UltraMount® Electrical Tester as a timesaving option for electrical system diagnosis. When using this tester, refer to the supplied instruction manual for proper use of the tester.

Any malfunction of the snowplow can be categorized as either mechanical, electrical or hydraulic. Mechanical issues are generally related to the blade, framework and mount components and are usually identified by visual inspection. Electrical and hydraulic issues can sometimes be difficult to trace to the component level and that is the purpose of this troubleshooting guide.

Read and understand the Theory of Operation before attempting troubleshooting.

TROUBLESHOOTING GUIDE

How to Use the Troubleshooting Guide

When diagnosing the snowplow electrical and hydraulic systems, many variables need to be eliminated in order to obtain workable test procedures. These variables translate into conditions listed before the tables or flow charts and must be satisfied before proceeding.

If the listed conditions are not met, the procedure can result in inaccurate results and wasted time.

In many cases, satisfying the listed conditions alone will solve the problem.

1. Go to the General Diagnostic Table and satisfy the nine listed conditions. These conditions must be met before proceeding into the table or to any subsequent test.
2. Locate the condition in the table which best describes the problem and check possible causes and actions in the order listed.
3. Proceed to a service procedure, another condition, or a specific test as directed. All tests except the Hydraulic System Test use a flow chart format. To use these flow charts, first satisfy any listed conditions at the top of the page. Then begin at the upper left square and proceed as directed.
4. Follow along sequentially through the table and tests, referring to the hydraulic and electrical schematics in the Theory of Operation section and the component Identification and Location diagrams. Eventually the problem will be pinpointed at the component level.

Electrical Testing

Read and understand the Theory of Operation section. A simple 12V test light with a ground lead can be used for circuit testing. When directed to check for 12 volts (12V), ground the test lamp lead and probe the terminal. When asked to check for ground, attach the test lamp lead to +12V and probe the terminal. Note that 12V is a nominal value. If using a voltmeter, actual voltage will vary with the vehicle and presence of loads in tested circuits. Continuity alone does not guarantee a good circuit. Poor connections or damaged wires may have continuity but be unable to carry sufficient current.

GENERAL DIAGNOSTIC TABLE

BEFORE USING THIS GENERAL DIAGNOSTIC TABLE OR PERFORMING ANY TESTS, YOU MUST VERIFY THE FOLLOWING CONDITIONS:

1. Snowplow is attached to vehicle and all harnesses are connected.
2. Harness connector pins and terminals are free of corrosion, insuring good connections, and coated with dielectric grease.
3. Vehicle battery and charging system are in good condition and battery connections are clean and tight.

⚠ CAUTION

Do not mix different types of hydraulic fluid. Some fluids are not compatible and may cause performance problems and product damage.

4. Hydraulic reservoir is filled to filler plug level with recommended fluid, when lift cylinder is fully retracted. See Product Specifications.

5. There are no oil leaks from hoses, fittings, cylinders or the hydraulic unit.
6. All built up snow and ice is removed from the snowplow.
7. 6 amp fuse in vehicle harness is good.
8. Ignition is turned on or engine is running.
9. The control is connected in the cab and turned on.

39

CONDITION	POSSIBLE CAUSE	ACTION
Motor does not run for any requested function.	Poor connections in vehicle or snowplow battery cables.	Clean and re-establish connections.
	Motor worn or damaged or pump seized.	Go to Motor Test.
	Motor relay inoperative.	Go to Motor Relay Test.
	Open circuit in vehicle wiring harness.	Go to Vehicle Harness Test - Motor Relay.
	Malfunctioning controller.	Go to Control Test.
Motor runs continuously.	Motor relay sticking or always energized.	Go to Motor Relay Test.
	Short circuit in vehicle wiring harness.	Go to Vehicle Harness Test - Motor Relay.
	Malfunctioning controller.	Go to Control Test.
Snowplow won't raise – motor runs.	Clogged pump filter (all functions are affected).	Clean or replace filter, flush reservoir.
	Pump relief low. Worn or damaged pump.	Go to Pump Pressure Test.
	Poor connections on battery cables.	Inspect battery cables, clean and re-attach all connections.

GENERAL DIAGNOSTIC TABLE

CONDITION	POSSIBLE CAUSE	ACTION
Snowplow won't raise – motor runs. (cont.)	Solenoid valve coil not activating properly.	Go to Solenoid Coil Activation Test.
	Hydraulic system malfunction.	Go to Hydraulic System Test.
	Malfunctioning controller.	Go to Control Test.
Snowplow raises slowly or partially – motor runs.	Clogged pump filter (all functions are affected).	Clean or replace filter, flush reservoir.
	Pump relief low. Worn or damaged pump.	Go to Pump Pressure Test.
	Poor connections on battery cables.	Inspect battery cables, clean and re-attach all connections.
	Slow motor RPM	Repair or replace motor.
	Air in lift cylinder	Check diffuser screen. Fully collapse lift cylinder to purge air.
	Malfunctioning controller.	Go to Control Test.
Snowplow will not lower or lowers slowly, or won't float.	Quill adjusted in too far.	Adjust quill out.
	Solenoid valve coils not activating properly.	Go to Solenoid Coil Activation Test.
	Hydraulic system malfunction.	Go to Hydraulic System Test.
Snowplow angles slowly.	Clogged pump filter (all functions are affected).	Clean or replace filter, flush reservoir.
	Pump relief low. Worn or damaged pump.	Go to Pump Pressure Test.
	Poor connections on battery cables.	Inspect battery cables, clean and re-attach all connections.
	Slow motor RPM	Repair or replace motor.
	Air in angle cylinder	Check diffuser screen. Cycle angle functions to purge air.
	Oil bypassing cylinder relief valve.	Go to Relief Valve Inspection and Adjustment.
	Malfunctioning PO check valve.	Go to Pilot Operated Check Valve Test and Inspection.
Blade will not hold angled position	Air in angle cylinders	Check diffuser screen. Cycle angle functions to purge cylinders.
	Oil bypassing cylinder relief valve.	Go to Relief Valve Inspection and Adjustment.
	Hydraulic system malfunction.	Go to Hydraulic System Test.
Plow does not perform the selected function or performs a different function.	Hydraulic hose routing incorrect.	Verify correct hose installation. See Hose Routing Diagram.
	Solenoid valve coils not activating properly.	Go to Solenoid Coil Activation Test.
	Hydraulic system malfunction.	Go to Hydraulic System Test.
	Malfunctioning Controller.	Go to Control Test.

GENERAL DIAGNOSTIC TABLE

CONDITION	POSSIBLE CAUSE	ACTION
Vehicle harness 6 amp fuse blows.	Red wire in vehicle harness is shorted to ground.	Repair wire or replace vehicle harness.
	Motor relay primary coil shorted internally.	Check primary coil with ohmmeter. Replace defective motor relay.
	Solenoid valve coil shorted internally.	Go to individual coil test. Replace shorted coils.
	Motor relay or solenoid coil wires in vehicle harness shorted to ground.	Repair wire or replace vehicle harness.
	Solenoid coil wires in plow harness shorted to ground.	Repair wire or replace plow harness.
	Malfunctioning controller.	Go to Control Test.
Vehicle accessory fuse blows.	Circuit overloaded.	Consult vehicle owner's manual for correct application of aftermarket electrical loads.
Excessive load on vehicle electrical system while using snowplow.	Poor connections in battery cables.	Inspect battery cables, clean and re-establish all connections.
	Pump relief incorrectly adjusted.	Go to Pump Pressure Test.
	Worn or damaged pump or motor.	Go to Pump Pressure Test/check motor.
Snowplow headlamps operate irregularly or not at all – snowplow attached. -or- Vehicle headlamps operate irregularly or not at all – snowplow removed.	Burned out bulbs or corroded sockets.	Replace bulbs, clean contacts.
	Wires improperly connected to relays.	Review and correct wire installation. See Headlamp Test Diagram.
	Headlamp relay inoperative.	Go to Plow Headlamp Test or Vehicle Headlamp Test.
Vehicle daytime running lamps (DRLs) do not work – snowplow removed. ('98 and older vehicles)	Parking brake on. Or see vehicle Owner's Manual for Proper Operation.	Fully release parking brake.
	Power in DRL circuit has been interrupted.	Turn lamp and/or ignition switch on and off to cycle the DRL circuitry.
	No output from DRL module.	Repair vehicle electrical system.
Snowplow Park or Turn lamps operate intermittently or not at all – snowplow attached.	Burned out bulb, corroded socket(s) or poor electrical connection.	Replace bulbs/clean contacts. If necessary, go to Park/Turn Lamp test.

HYDRAULIC RAMS—INSPECTION AND REPAIR

General

The lift and angling rams use a gland nut with rod seal and o-ring instead of a packing set and adjustable packing nut. The gland nut is torqued onto the cylinder coupling and requires no adjustment. Periodically inspect rams for leakage. A slight amount of oil weep along the rod is normal and may leave an oil film around the gland nut. If oil is dripping off the gland nut or the wiper is extruded or folded in, the ram should be repaired.

Disassembly

1. Lower blade to ground and turn off vehicle ignition.
2. Before removing ram from snowplow, break gland nut loose with a 2-3/16 open-end wrench. If a pipe wrench must be used, set jaws squarely against flats of nut and apply steady force. Gland nut break-loose torque usually exceeds 200 ft-lb.
3. Remove ram and collapse to drain oil.
4. Remove gland nut and rod as an assembly. Remove split bearing and spacer and slide gland nut off bearing end of rod.
5. Remove o-ring, wiper, and seal from gland nut and discard them. Avoid scratching or damaging o-ring, wiper, and seal grooves.
6. Check screen in ram base for contaminants. Wash out and identify any foreign material to determine if further corrective action is needed.

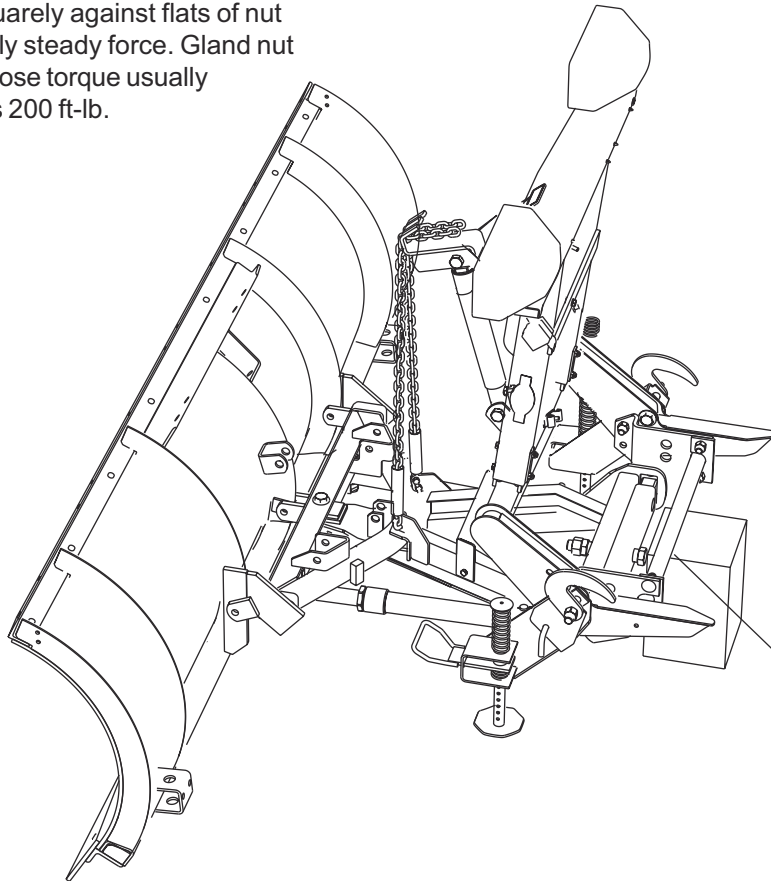

⚠ CAUTION
If plow is not attached to vehicle, install support blocking under 1-1/2" round cross tube at rear of lower lift frame before removing lift ram or lift chains.

HYDRAULIC RAMS—INSPECTION AND REPAIR

Inspection

1. Cylinder wall should be straight and free of any deep gouges or displaced material. O-ring chamfer and coupler end surface should be clean and smooth.
2. Split bearing sections and spacer should be free of burrs and sharp edges.
3. Check rod for rust or nicks that can damage the seal.
4. Gland nut o-ring, wiper, and seal grooves must be clean, smooth, and free of burrs. If o-ring flange is cracked or broken, replace gland nut.

Assembly

1. Always use a new seal, wiper and o-ring. Lubricate with clean hydraulic oil and assemble by hand to avoid seal damage. Be sure seal lip is toward the inside of the cylinder and the o-ring “spring” inside the seal in position. Follow instructions in the seal kit.
2. Lubricate bearing end of rod and insert into wiper end of gland nut. Press nut onto rod by hand, making sure the outer lip of the wiper does not fold in. Never slide nut over pin end of rod; this will damage the seal. Slide nut to middle of rod.

3. Assemble spacer and split bearing. Hold rod vertically so spacer holds bearing and assemble to cylinder. Tighten gland nut to 150-180 ft-lb. If a socket and torque wrench are not available, tighten nut by hand against a .012 feeler gauge between coupler and nut flange, remove gauge and tighten nut an additional 1/4 turn. This procedure is best accomplished with ram installed on plow.
4. Reinstall ram. For angle ram, align fitting 20° to the rear of vertical when ram is horizontal. For lift ram, with fitting to rear, align fitting to passenger side. See section on installing fittings and hoses for proper procedure.
5. Activate blade several times and fully collapse lift ram manually to remove air. Refill reservoir.

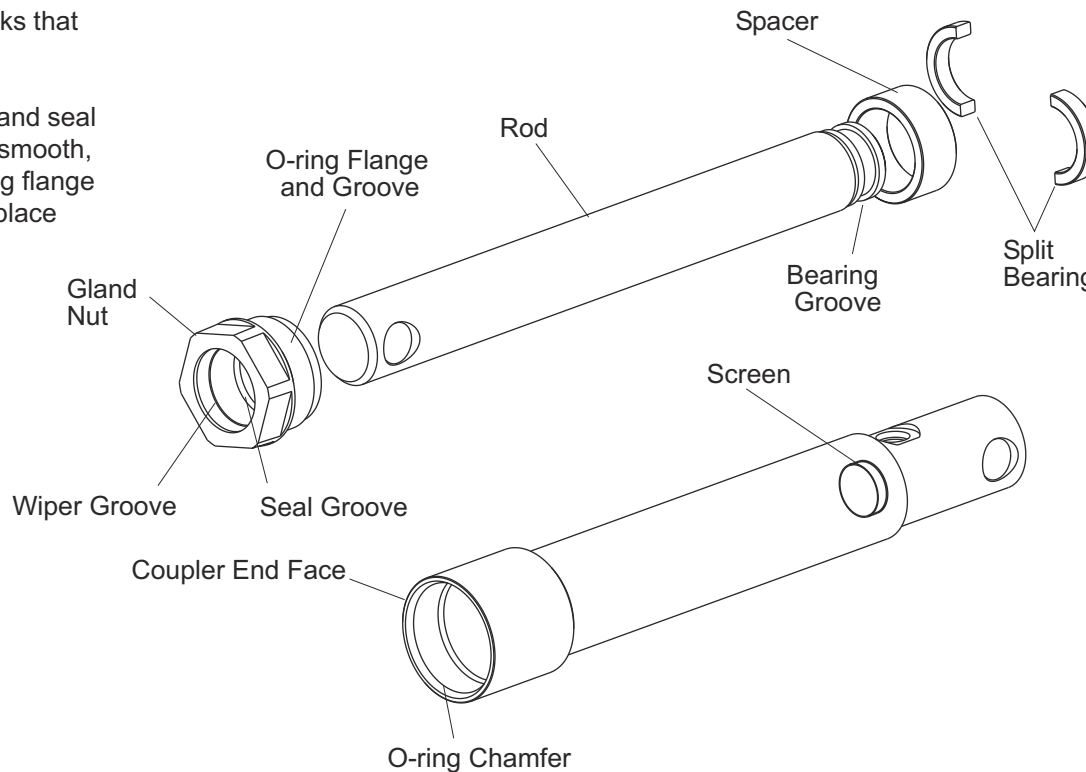

MOTOR TEST

⚠ WARNING

The driver shall keep bystanders clear of the blade during this test. Do not stand between the vehicle and the blade. A moving or falling blade could cause personal injury.

Refer to the Motor and Motor Relay Test Diagram on following page.

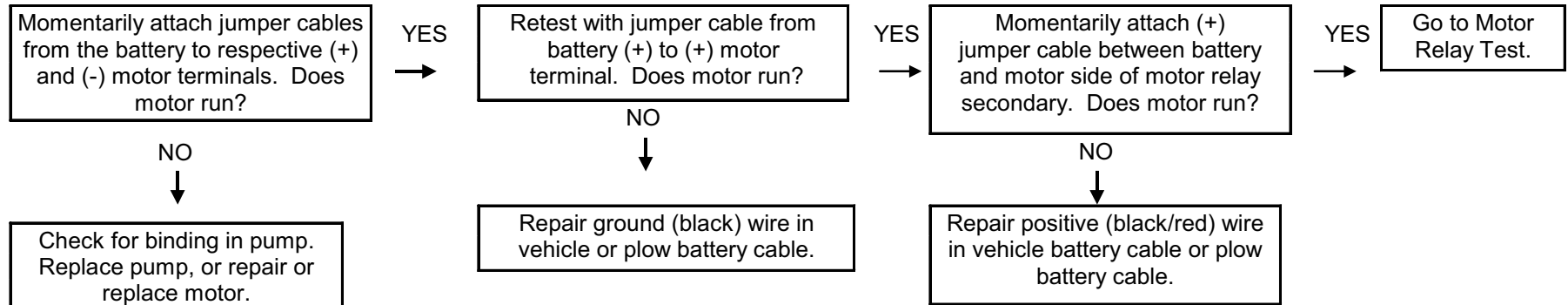

MOTOR AND MOTOR RELAY TEST DIAGRAM

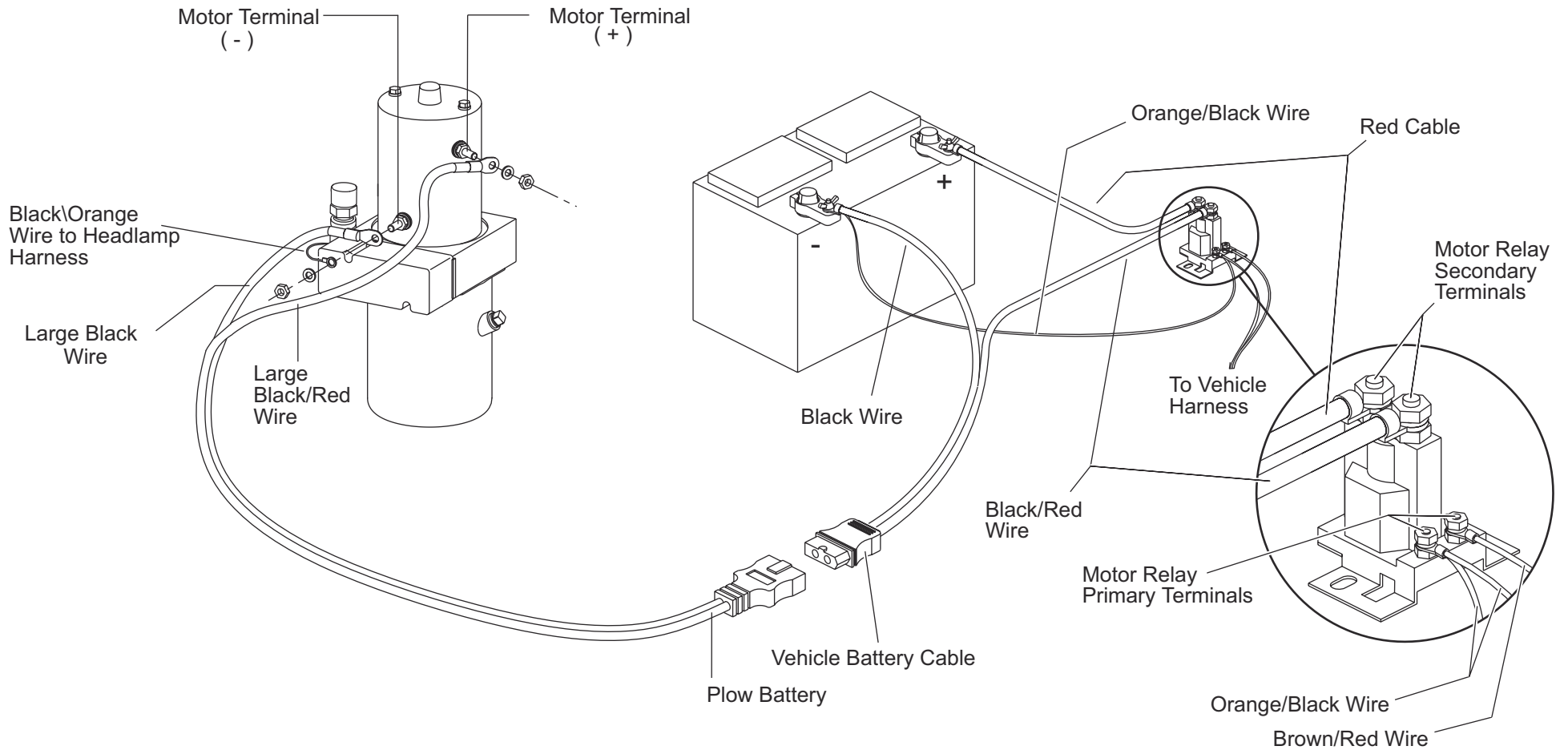

MOTOR RELAY TEST

⚠ WARNING

The driver shall keep bystanders clear of the blade during this test. Do not stand between the vehicle and the blade. A moving or falling blade could cause personal injury.

1. Momentarily jump power and ground directly from battery to motor to verify that the motor runs. Make final connection at the motor.
2. Refer to the Motor and Motor Relay Test Diagram (page 45), and Vehicle Harness and Vehicle Cable Location Diagram (page 12.)

Motor does not run:

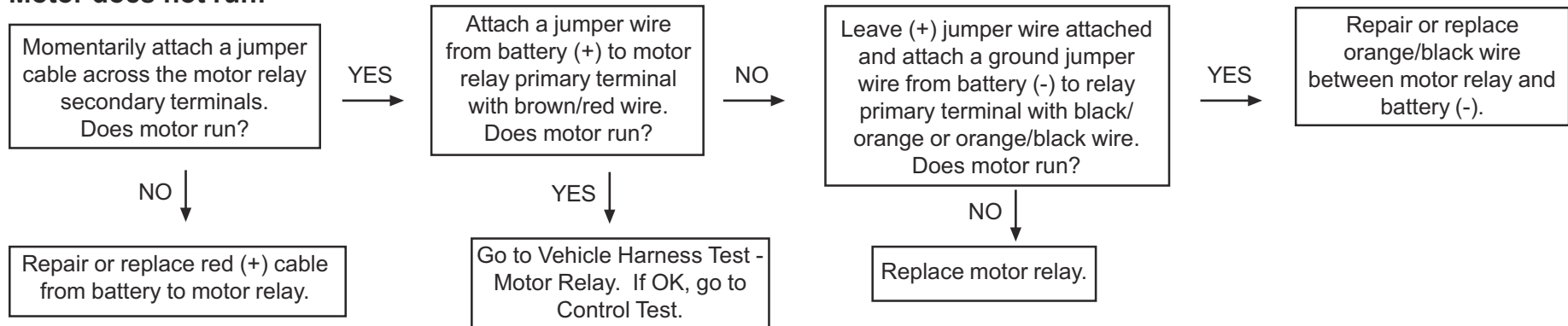

Motor runs continuously:

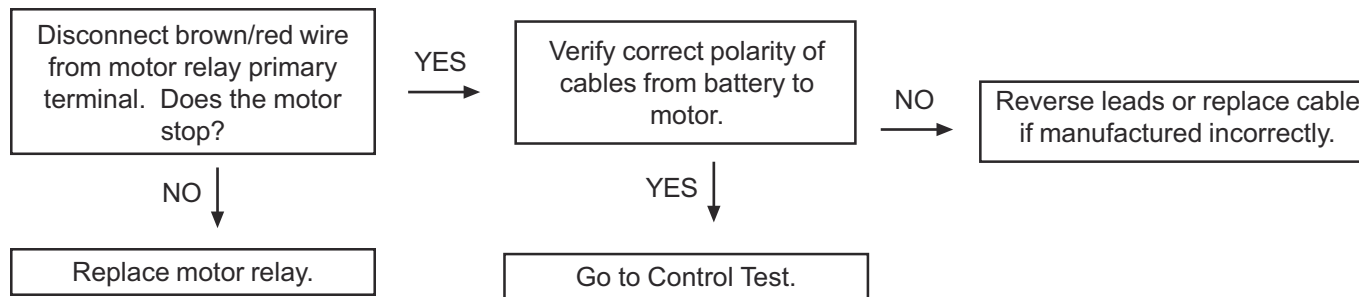

VEHICLE HARNESS TEST – MOTOR RELAY

⚠ WARNING

The driver shall keep bystanders clear of the blade during this test. Do not stand between the vehicle and the blade. A moving or falling blade could cause personal injury.

1. Perform the Motor Test and Motor Relay Test first.
2. Disconnect the control in the cab.
3. Refer to the 6-Pin Connector diagram. Test the vehicle side of the connector in the cab as follows.

White 6-Pin Connector on vehicle harness—located in cab (end view)

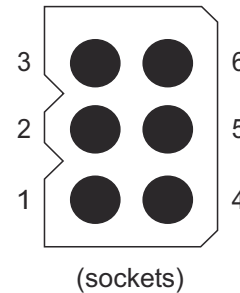

Pin #	Wire Color
1	Red
2	Lt Green
3	Orange/Black
4	Brown/Red
5	Lt Blue
6	White/Yellow

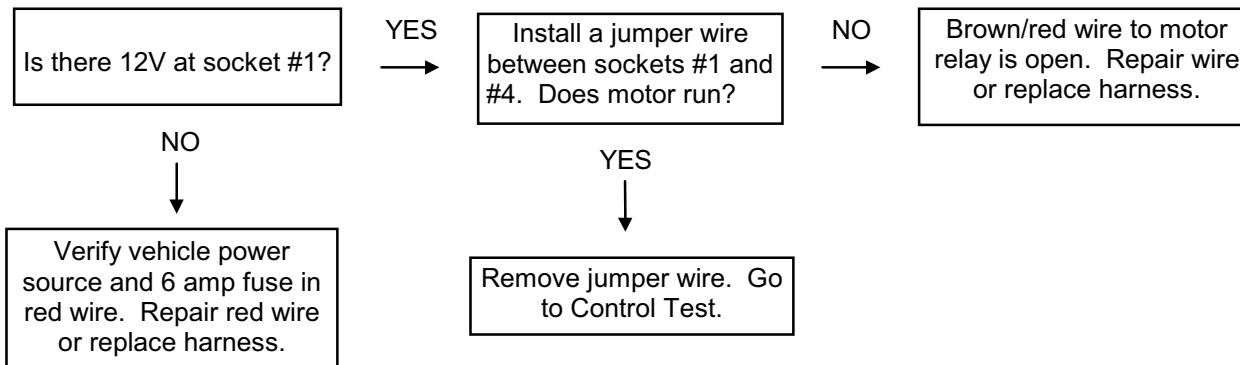

CONTROL TEST

Test Procedure for Hand-Held or Solenoid Control

1. Disconnect the control in the cab and remove to work bench.
2. Refer to the 6-Pin Connector diagram and the chart.
3. Using a 12V power source with a 6 amp fuse in the positive lead, carefully apply +12V to pin #1 and ground to pin #3 of the 6-Pin connector.
4. Turn the control on. Power indicator lamp should be lit. Using a grounded test light, check for 12V at each of pins #2, 4, 5, 6 when the control is activated for each function. Footnotes in the chart indicate special conditions of control operation.
5. Compare the control outputs for all functions with the chart and proceed to the flow chart on the following page.

Pin No.	Purpose	Angle Right (c)	Angle Left (c)	Raise (d)	Lower/Float (e)
1	12V Input				
2	S2 Output (3-Way)	ON	ON		
3	Ground				
4	Motor Relay Output	ON (b)	ON (b)	ON (b)	
5	S3 Output (4-Way)		ON	ON	
6	S1 Output (2-Way)	(a)	(a)		ON

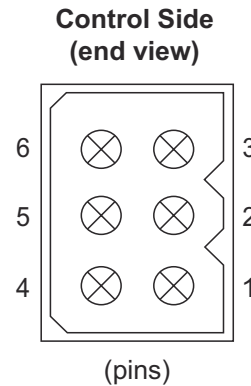

Wire Color		
Pin #	Solenoid Control	CabCommand
1	White	Black/White
2	Green	Red
3	Brown	Green
4	Black	Orange
5	Blue	Blue
6	Red	Yellow

- a. S1 output will be ON if control is in float. Activate raise function to cancel float. If hand-held control is in float, S1 output will turn off while angle button is pressed and on when the button is released.
- b. For hand-held control, motor relay output turns off before solenoid coil outputs when button is released.
- c. For hand-held control, outputs turn off after button is held for approximately 9.6 seconds.
- d. For hand-held control, outputs turn off after button is held for approximately 4.8 seconds.
- e. Solenoid control activates S1 output in float when lever is moved to lower position. Hand-held control activates float when lower button is held for .75 second.

CONTROL TEST

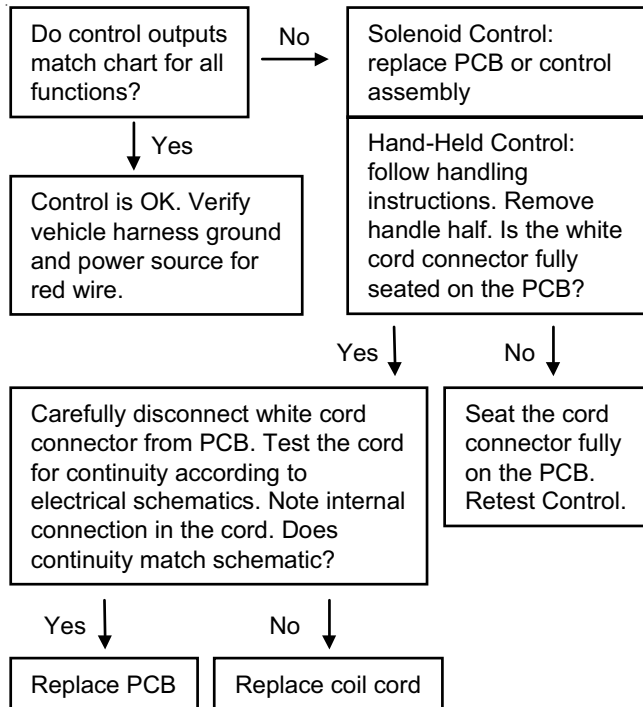

NOTE: For hand-held control, poor ground connections or high or low voltage will shut the control off.

To Safely Handle Hand-Held PCB:

⚠ CAUTION

Printed circuit board (PCB) is subject to damage from static electricity. Follow instructions below to safely handle PCB.

1. Disconnect the control in the cab and remove to a workbench.
2. Place control on its left side and remove right side of handle, leaving the keypad/circuit board assembly in left half.
3. Touch hand to any grounded metal object to discharge possible static buildup.
4. Remove keypad/circuit board assembly from housing by only touching the edges of the keypad/circuit board assembly.
5. The keypad/circuit board assembly can be handled safely as long as contact with it is maintained.

PUMP PRESSURE TEST

⚠ WARNING

The tester shall keep bystanders clear of the blade during this test. Do not stand between the vehicle and the blade. A moving or falling blade could cause personal injury.

1. Lower blade to the ground, place control in FLOAT mode, and fully collapse the lift ram.
2. Carefully disconnect either angle hose from the angle ram 90° fitting and install Pressure Testing Kit #56679 according to kit instructions or refer to FloStat® Hydraulic Hose Routing and Fitting Installation instructions on page 7.
3. Route the end of the hose with gauge up to the headlamp crossbar and secure prior to testing.
4. Tighten hydraulic fittings to proper torque as described on page 7.
5. Activate the appropriate angle function with the control and read the pump relief pressure when the blade is fully angled.

6. Refer to the illustration for pump relief valve location. Adjust pump pressure according to chart value. Do not adjust relief valve while motor is running.
7. Proceed to the flow chart on the following page.

Plow Type	Maximum Motor Amp Draw At 11.2 Volts w/Warm Oil	Pump Relief Valve Pressure (± 50 PSI)
Standard, Pro, PRO PLUS™	200	1750

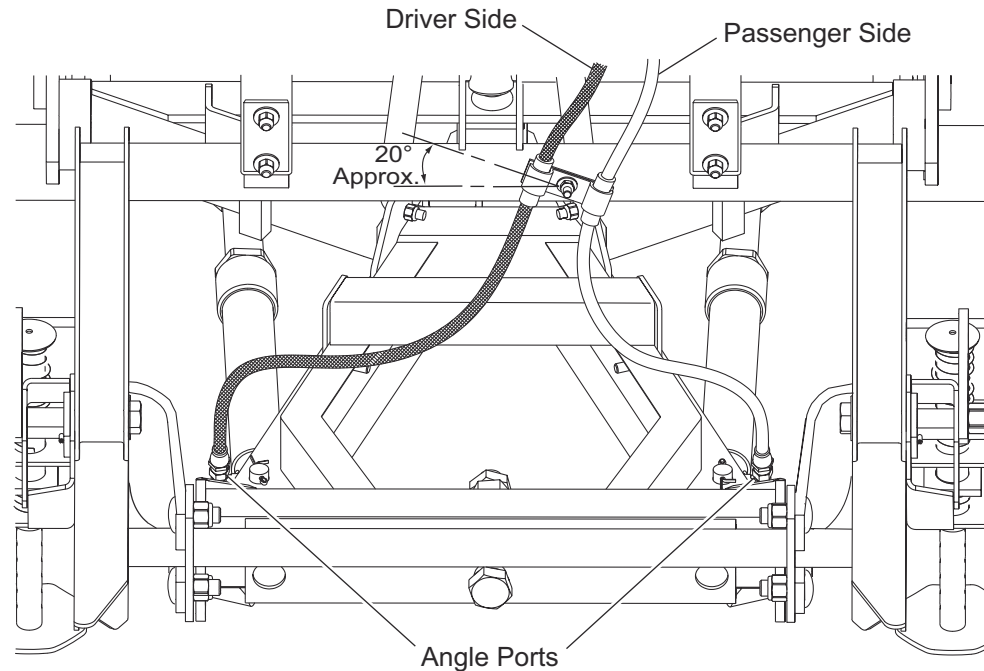

PUMP PRESSURE TEST

1. Be sure motor is in good condition.

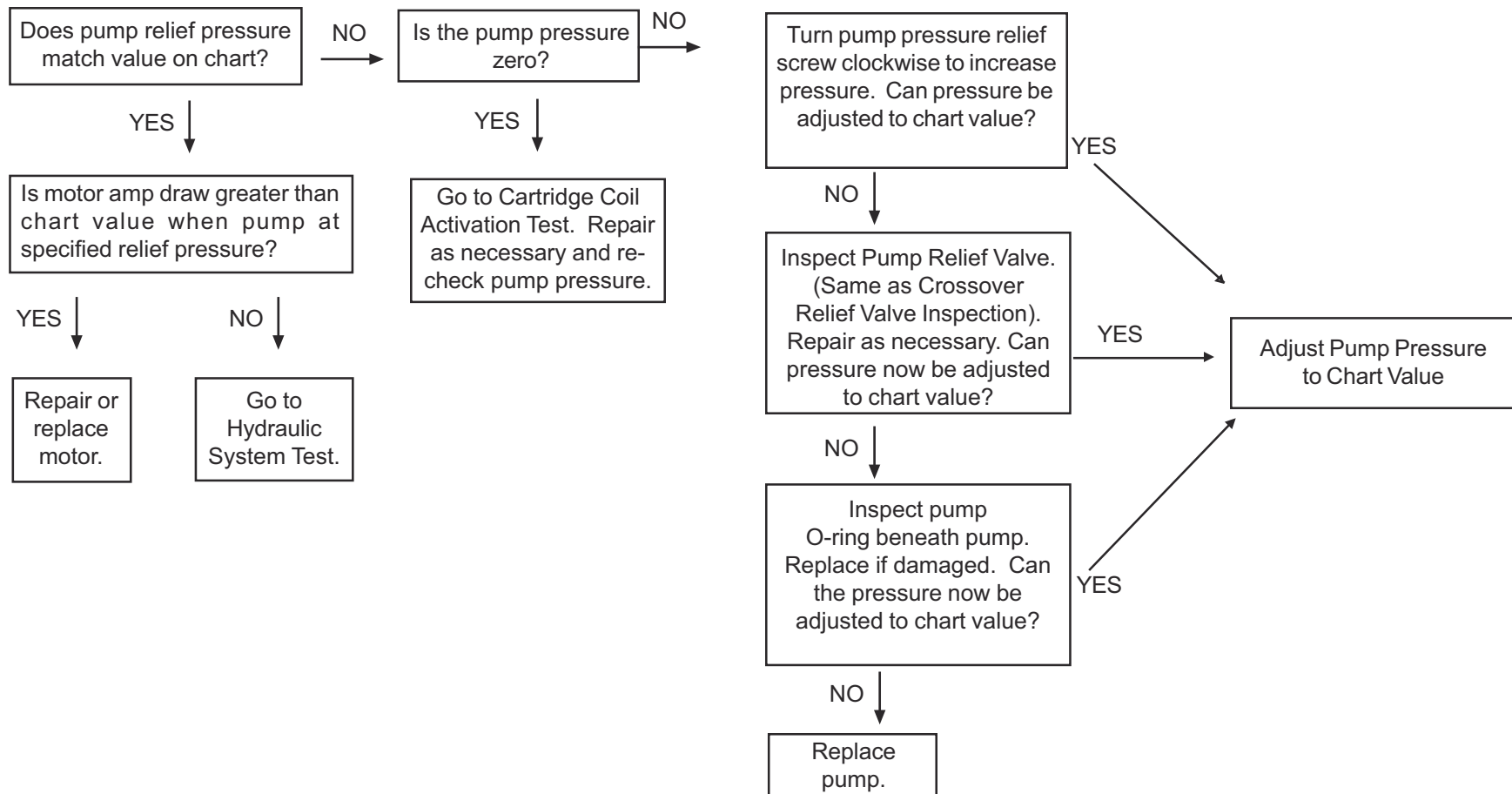

CARTRIDGE COIL ACTIVATION TEST

1. Disconnect the black/red (+) battery cable from the motor and isolate it.
2. Remove solenoid valve cover.
3. Verify wires are properly attached to solenoid coils. Refer to Wire Connection Table, Electrical Schematic, and Solenoid Cartridge Valve Identification and Location.
4. Activate the control for each function and check for magnetic pull at all three solenoid valve coils. Only the coils designated as "ON" in the table should activate for each function. After noting which coils are energized, proceed to the flow chart.

Cartridge Coil Wiring and Activation – Wire Connection Table

Solenoid Coil	Plow Harness Pin	Wire Color	Angle Right	Angle Left	Raise	Lower
S1 (2-Way)	1	White/ Yellow	*	*	*	ON
S2 (3-Way)	3	Light Green	ON	ON		
S3 (4-Way)	4	Light Blue		ON	ON	

*S1 output will be "ON" for all functions if control is in "FLOAT".

Activate "RAISE" function to cancel "FLOAT".

Hand Held Control Only – While in "FLOAT", pressing and holding the "RIGHT" or "LEFT" button will turn off the solenoid cartridge valve S1 until the button is released.

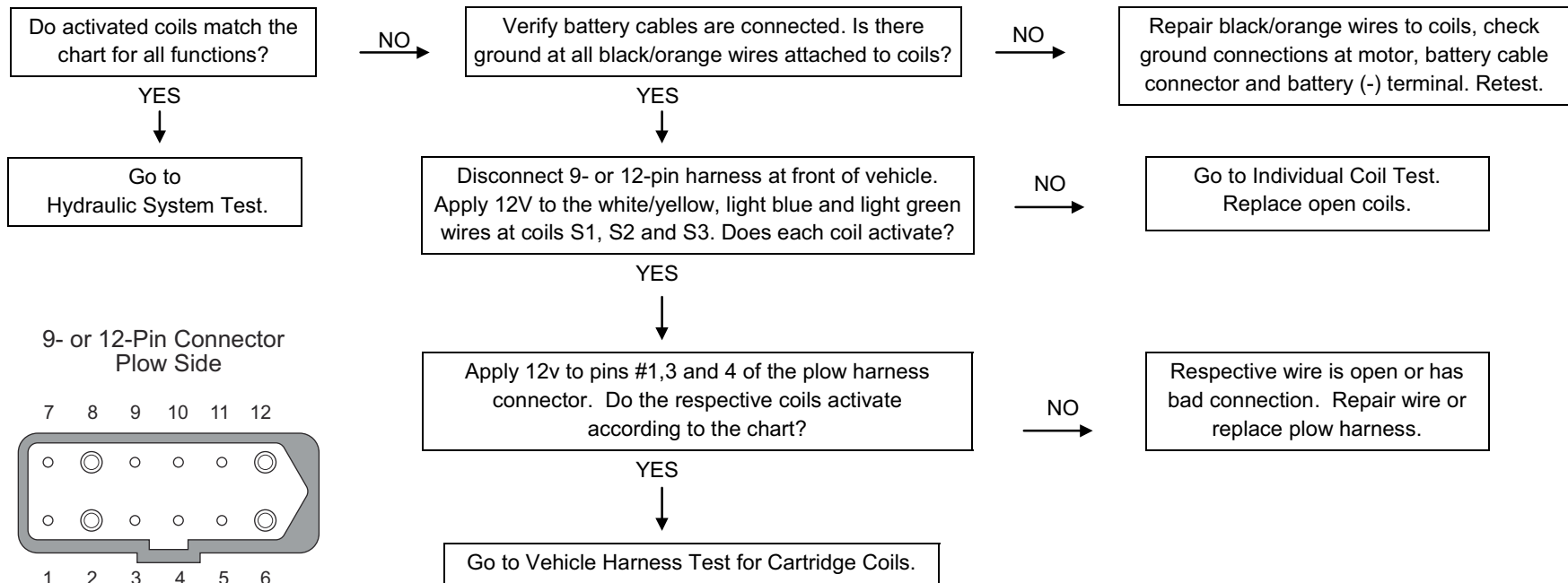

VEHICLE HARNESS TEST – CARTRIDGE COILS

1. Disconnect the black/red (+) battery cable from the motor and isolate it.
2. Perform Cartridge Coil Activation Test.
3. Connect all harness connectors at the front of the vehicle.
4. Refer to the 6-Pin Connector diagram for socket location.

White 6-Pin Connector on vehicle harness—located in cab (end view)

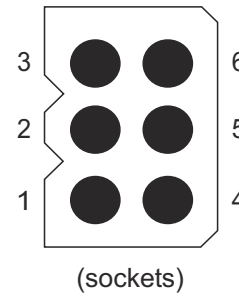

Pin #	Wire Color
1	Red
2	Lt Green
3	Orange/Black
4	Brown/Red
5	Lt Blue
6	White/Yellow

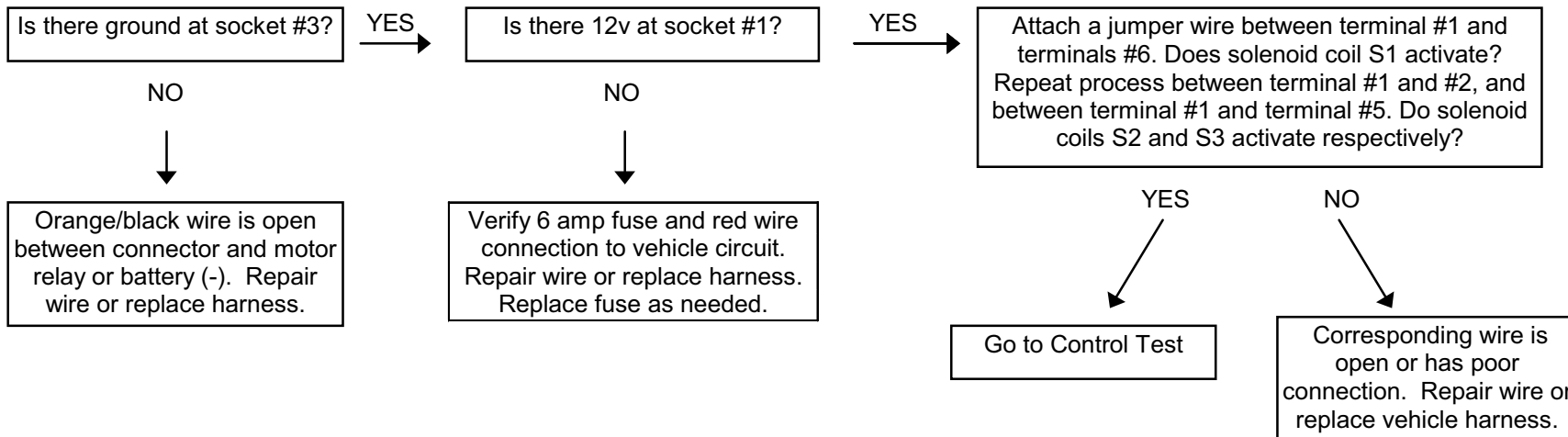

HYDRAULIC SYSTEM TEST

This test consists of trying all the plow functions and comparing the plow reaction to the action requested in the following table. The table will pinpoint a solenoid valve or poppet check valve problem accurately if only one component is malfunctioning. If the plow reaction for a given function is not listed in the table, there may be a crossover relief or poppet check valve which is stuck open or contaminated, missing or damaged

O-rings or backing rings on cartridge, crossover relief or poppet check valve spool, or there may be two or more malfunctioning components. In this case, use the specific function hydraulic schematic and carefully inspect each component in the flow circuit. If contamination is evident in more than one component, the hydraulic unit, hoses and cylinders must be completely disassembled, inspected and cleaned.

1. Perform Cartridge Coil Activation Test first.
2. Verify hydraulic hose installation is correct. Refer to the Hose Routing diagram.
3. Test all of the plow functions.
4. Inspect and clean or replace the suspected component. Refer to the Hydraulic Parts Diagram -page 8.

5. Refer to the sections following the table for inspection and adjustment of solenoid cartridge valves, poppet check valve and crossover relief valves.

IMPORTANT: *When testing the plow functions, be sure the control is not in "float."*

ACTION REQUESTED	PLOW REACTION	POSSIBLE CAUSE
Raise	None	S3 not shifted
	Angle Left	S2 stuck shifted
Lower	None	S1 not shifted
		S2 stuck shifted
		S3 stuck shifted
Angle Right	Angle Left	S3 stuck shifted
	None	S2 not shifted
	Slow	Poppet check valve not opening
Angle Left	Angle Right	S3 not shifted
	Raise	S2 not shifted
	None	S2 and S3 not shifted
	Slow	Poppet check valve not opening
None (blade raised)	Lowers	S1 stuck shifted or has leaking internal check valve
None	Drifts Right	S2 stuck shifted
		Contamination, bad valve stem seat, or damaged O-rings in crossover relief valve
	Drifts Left	Poppet check valve open
		Contamination, bad valve stem seat, or damaged O-rings in crossover relief valve

CROSSOVER RELIEF VALVE INSPECTION AND ADJUSTMENT

Crossover Relief Valve Inspection

1. Remove the valve stem, ball, spacer and spring.
2. Look for broken or damaged parts, contamination or missing or damaged O-rings. Check valve stem seat for excessive wear.

⚠ CAUTION

Be careful to strike the stem squarely. You can bend the stem if you do not strike it squarely.

3. If parts are in good condition, place ball on hard wood block, hold stem seat on ball, and strike stem lightly with a hammer. This will re-conform the seat to the ball.
4. Apply a light coat of anti-seize or grease to stem threads. Lubricate O-ring with hydraulic fluid. Reassemble components into valve block.

Adjustment

1. Adjust by tightening the relief valve stem until it bottoms out (until spring is fully compressed).
2. Back off valve stem (rotate counterclockwise) the number of turns indicated in the Crossover Relief Valve Settings chart.

Crossover Relief Valve Settings

Plow Type	No. of Turns Backed Off (CCW) From Fully Seated*	Crossover Relief Valve Pressure (± 100 PSI)
Standard, Pro, PRO PLUS™	1-1/4 – 1-1/2	4000

* Settings are approximate.

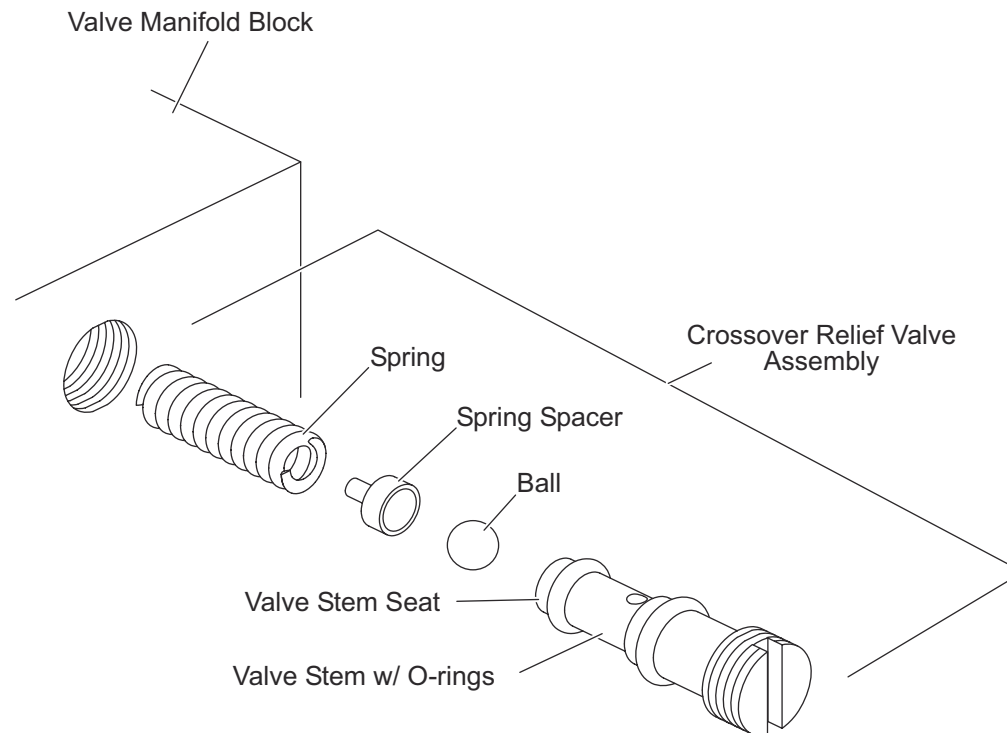

PILOT-OPERATED (POPPET STYLE) CHECK VALVE TEST AND INSPECTION

Test

1. Remove poppet and poppet spring. Reinstall boss plug and test plow. If problem is corrected go to inspection.

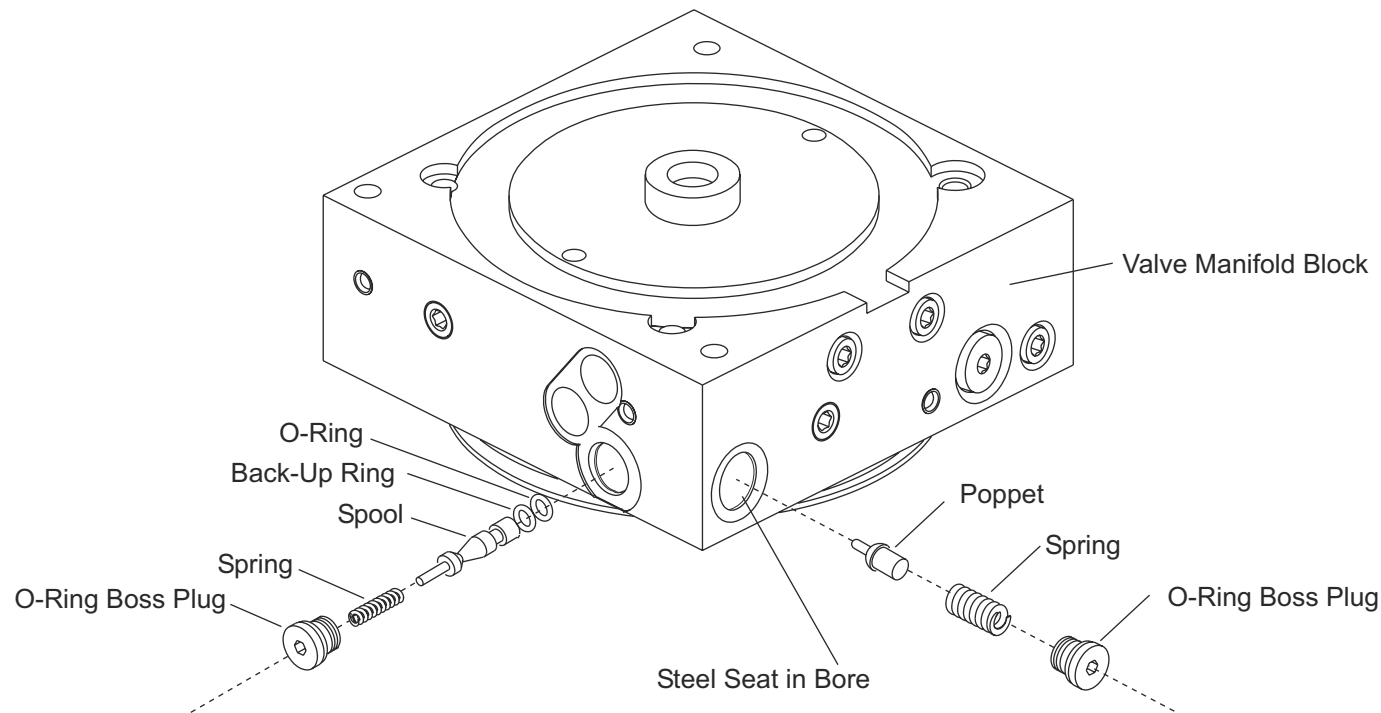

Inspection

1. Strike boss plugs squarely with a hammer to facilitate removal.
2. Remove O-ring boss plug, spring and poppet.
3. Remove O-ring boss plug, spring and spool with O-ring. Use long/slender needle-nosed pliers to remove spool.
4. Inspect springs, poppet, spool, O-rings and poppet seat for wear, damage or contamination. Replace worn parts.
5. The valve manifold block has a pressed in steel poppet seat. Use a strong pencil magnet to push and pull on the seat. If the seat moves at all, replace the valve block. Never hammer on the seat or attempt to "coin" the poppet.
6. Re-oil O-rings, install spool fully into bore. Spool must insert smoothly.
7. Install poppet, springs and O-ring boss plugs. Torque O-ring boss plug to 60 in-lb.

INDIVIDUAL SOLENOID COIL TEST

1. Remove both wires from coil terminals.
2. Attach an ohmmeter across the coil terminals.
3. A reading of approximately 6.7 ohms indicates the coil is good. A good coil will draw approximately 1.5 amps.

SOLENOID CARTRIDGE VALVE INSPECTION

1. Remove coils from the solenoid cartridge valves and remove the cartridge valves from the manifold. Look for visible contamination or damaged seals. Check for stuck spools with a plastic, aluminum, or soft brass probe by pushing on the spring loaded internal spool from the end of the valve. The spool should move freely through its entire travel. Spool travel is approx. 0.070".

NOTE: Using probe to move spool may shear contamination which was affecting spool movement.

2. Bench test the cartridge valve by installing a coil on the stem and applying 12V and ground. Watch through the side ports for internal spool travel.

If the cartridge valve spool is stuck or its travel is restricted, replace the cartridge. If the cartridge valve appears to be in good condition, clean it with parts cleaning solvent and dry with compressed air, being careful not to damage the seals. **Check the spool travel again in case any internal contaminants were dislodged during cleaning.**

Re-oil the cartridge valve seals and o-rings and reinstall the cartridge valve, torquing to 10 ft-lb. Install the coils and torque the retaining nuts to 4 ft-lb.

NOTE: If contamination is seen in more than one component, it can reasonably be assumed that the entire system is contaminated. In order to perform a proper repair, the entire hydraulic unit, including hoses and cylinders, must be disassembled and cleaned. The source of the contamination must be located and repaired before reassembly.

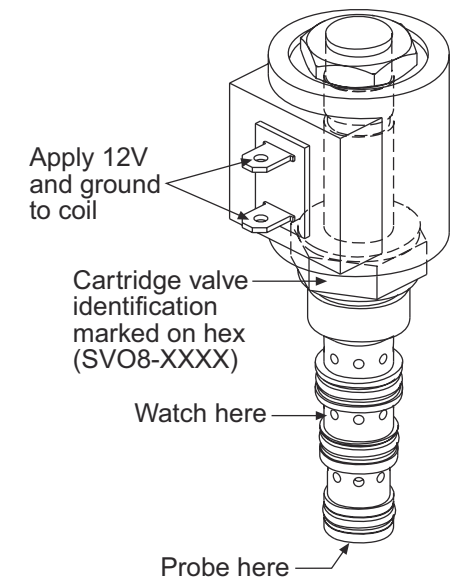

HEADLAMP TEST DIAGRAM – 9-PIN HARNESS

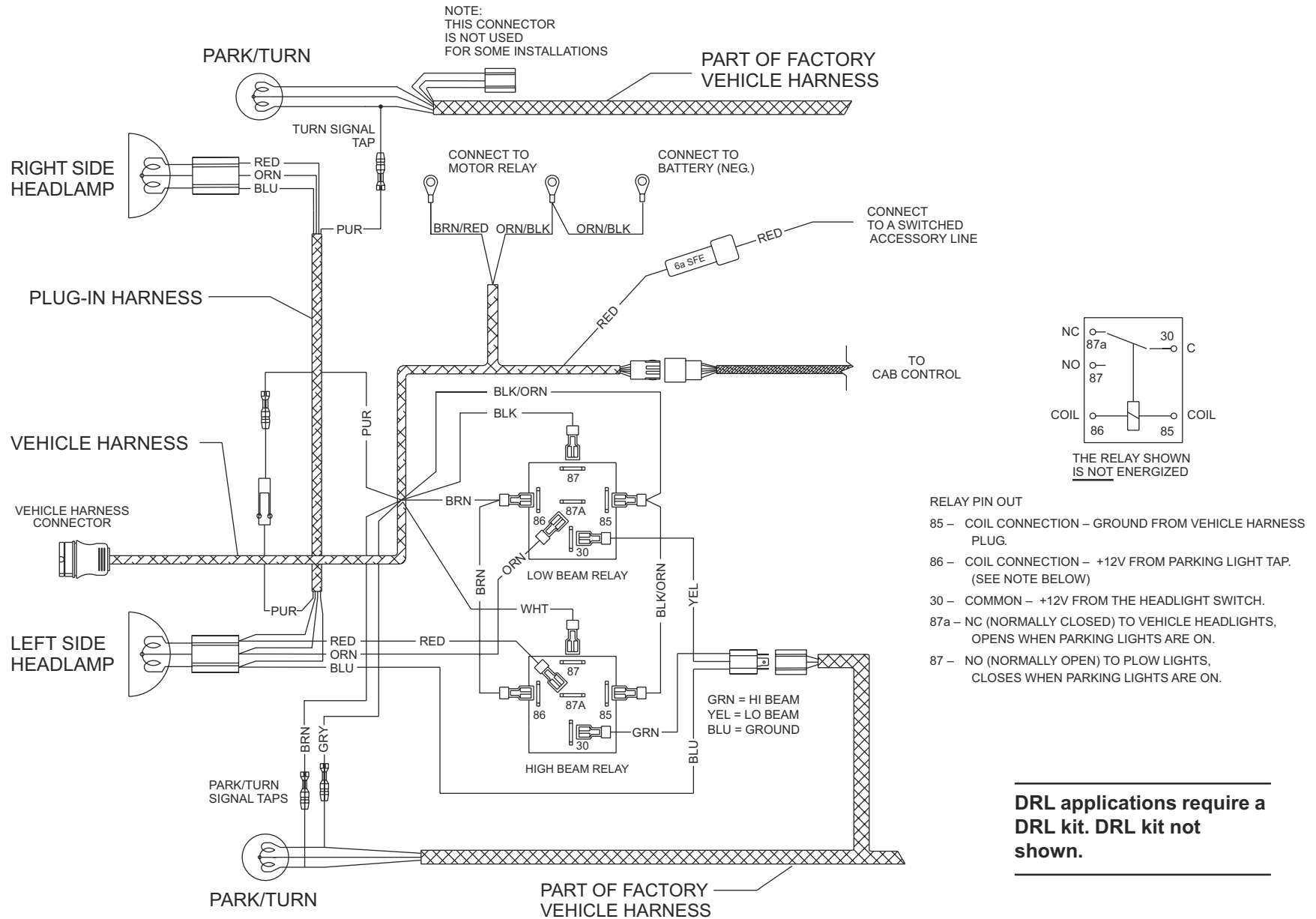

VEHICLE HEADLAMP TEST – 9-PIN HARNESS

1. Verify correct harness and wire installation to relays and vehicle headlamps. See the Headlamp Test Diagram – 9-Pin Harness. The specific wiring diagram for the vehicle can be found in the

plow installation instructions, or the manual *Electrical Schematics Guide*.

2. Turn ignition and headlight switch on.

4. All bulbs must be good.

3. Disconnect all harnesses at the front of the vehicle.

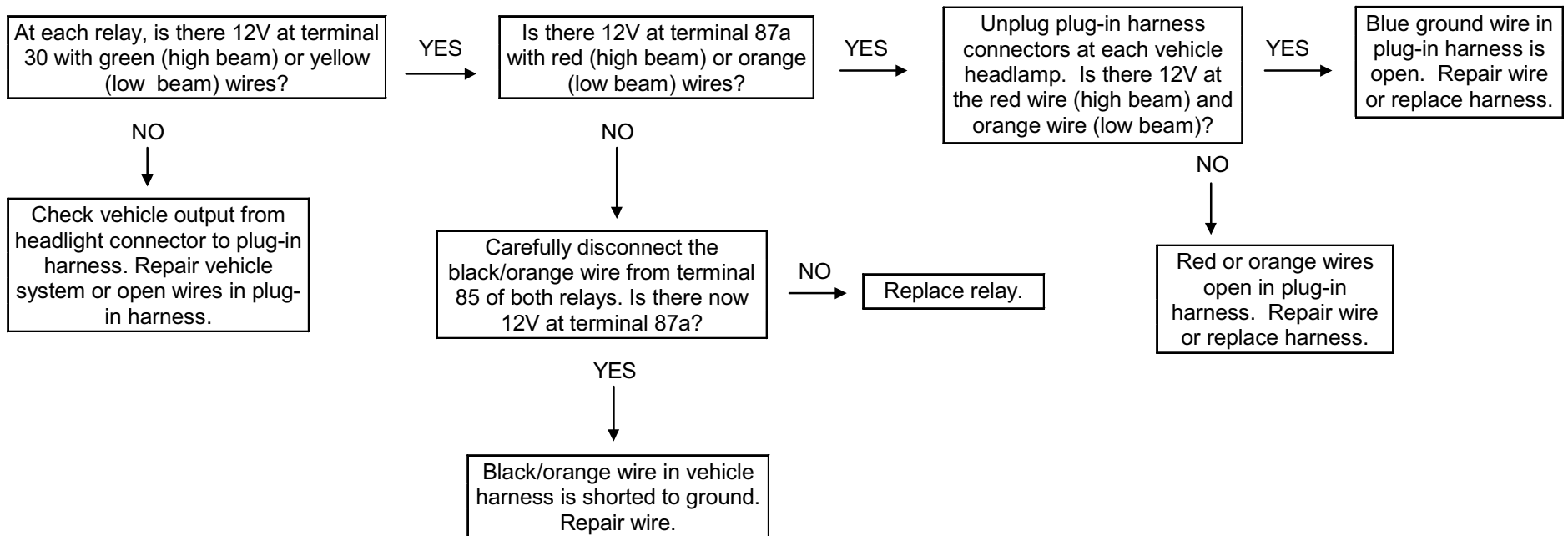

PLOW HEADLAMP TEST – 9-PIN HARNESS

- Verify correct harness and wire installation to the headlamp relays.
- All bulbs must be good.
- Connect all harnesses at the front of the vehicle.
- Turn vehicle headlamp switch on. For vehicles with Daytime Running Lamps (DRLs), turn ignition on. DRL equipped vehicles have a pink wire instead of a brown wire on relay terminal 86.
- Refer to the 9-Pin Electrical Schematic Headlamp Test Diagram – 9-Pin Harness, and Connector diagram. The specific wiring diagram for the vehicle can be found in the plow installation instructions, or the manual *Electrical Schematics Guide*.

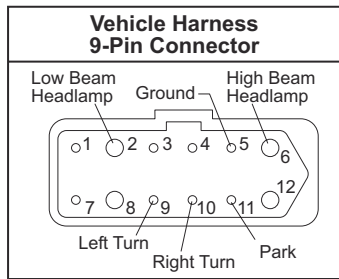
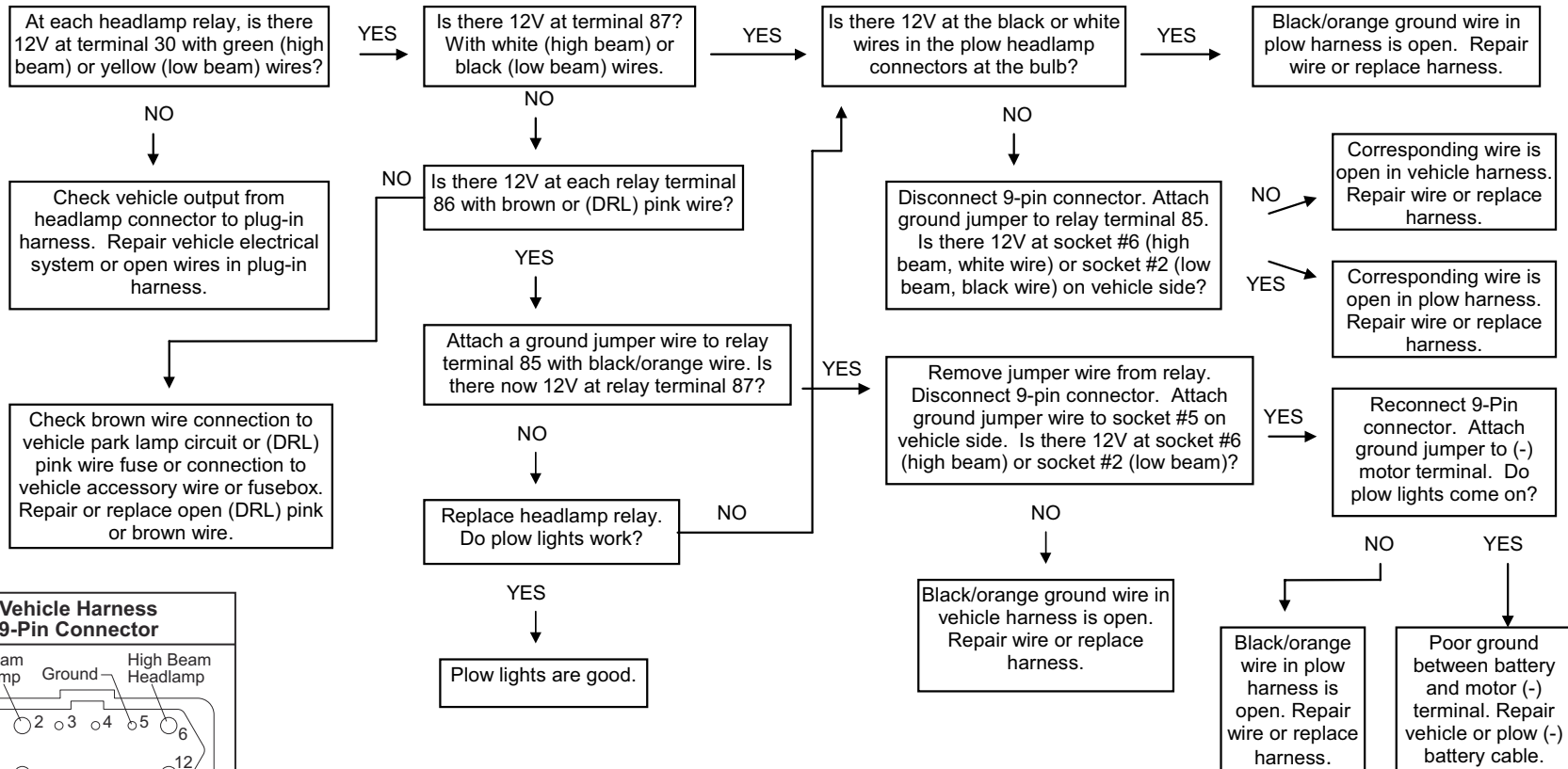

PARK/TURN LAMP TEST – 9-PIN OR 12-PIN HARNESS

1. Verify plow park/turn (P/T) bulbs and contacts are good.
2. Turn parking lamps and ignition on.
3. Connect all harnesses at the front of the vehicle.
4. Refer to the Vehicle Harness 9- or 12-Pin Connector diagram.

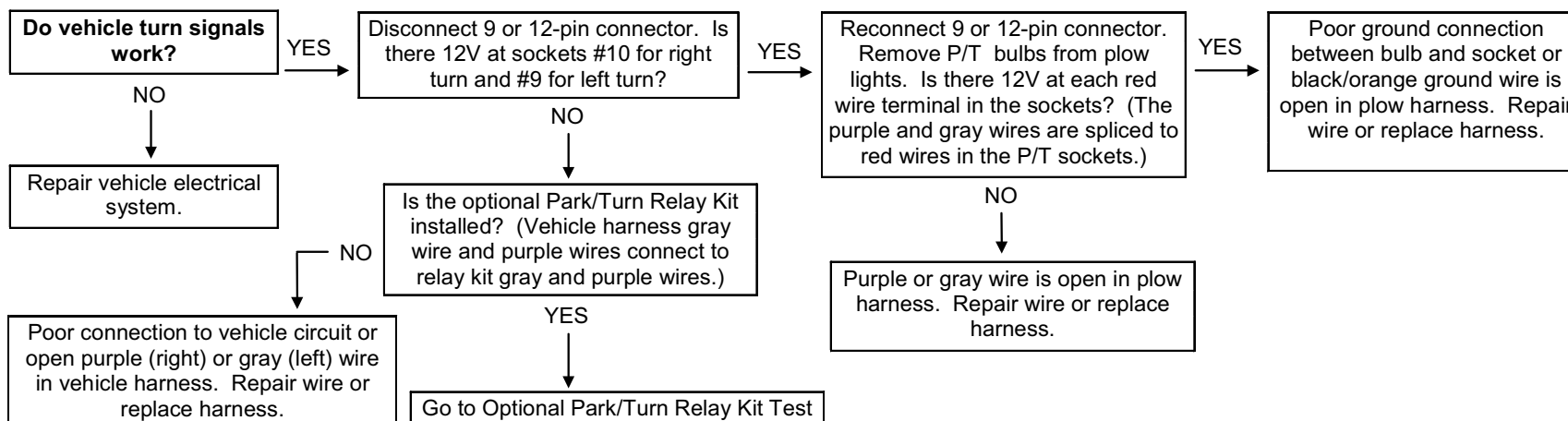
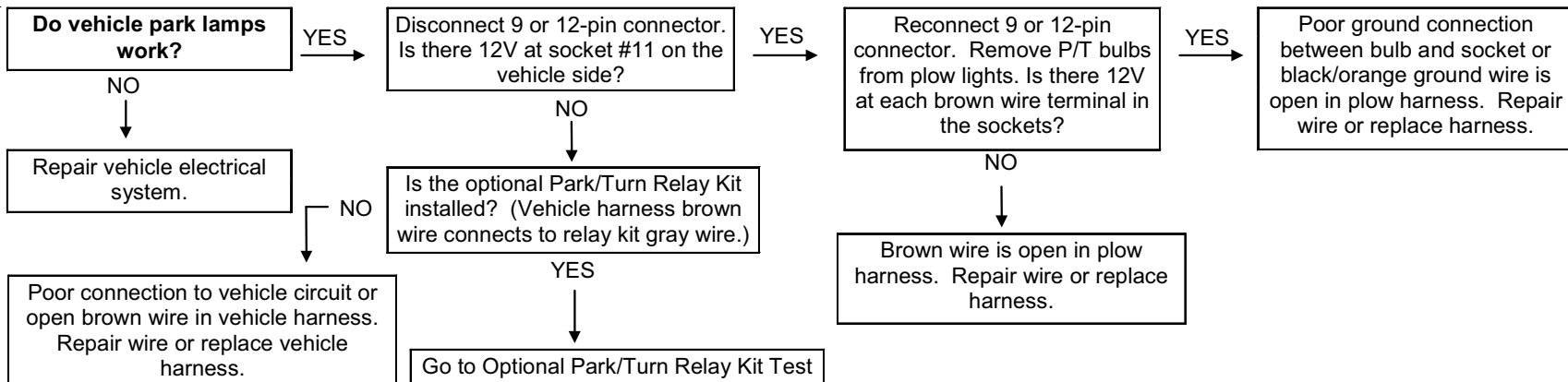
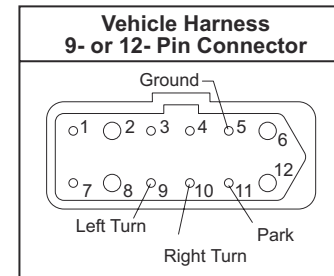

OPTIONAL PARK/TURN RELAY KIT TEST

1. Turn signal applications use both gray and purple relay circuits.
2. Park lamp applications use gray relay circuit only. If gray relay circuit fails, purple relay circuit can be used instead.
3. Refer to the Optional Park/Turn Relay Kit schematic.
4. Verify that the relay kit red and black wires are connected to battery (+) and (-) terminals respectively.
5. Verify in-line 10 amp fuse in red wire is good.
6. Disconnect long and short gray and purple wires to isolate relay circuits.

NOTE: If the snowplow park/turn lamps are on when the vehicle park/turn lamps are off, replace the relay kit.

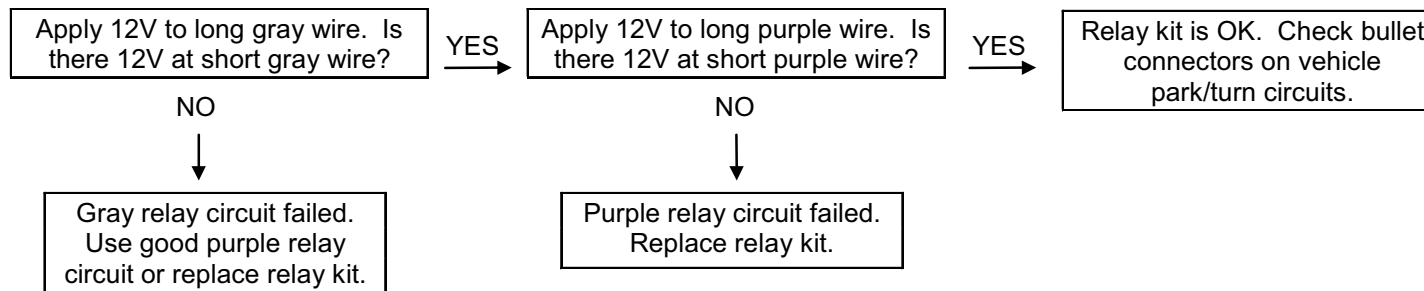

OPTIONAL PARK/TURN RELAY KIT SCHEMATICS

WIRED FOR PARK LAMPS

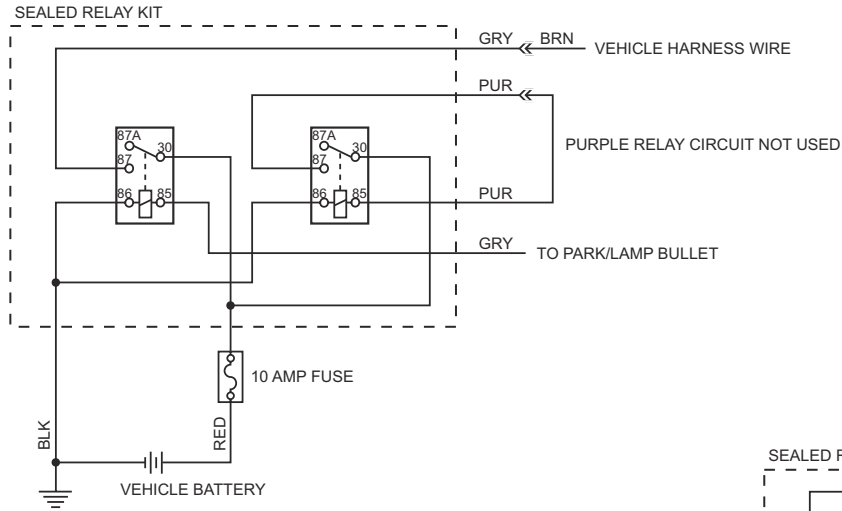

WIRED FOR TURN SIGNALS

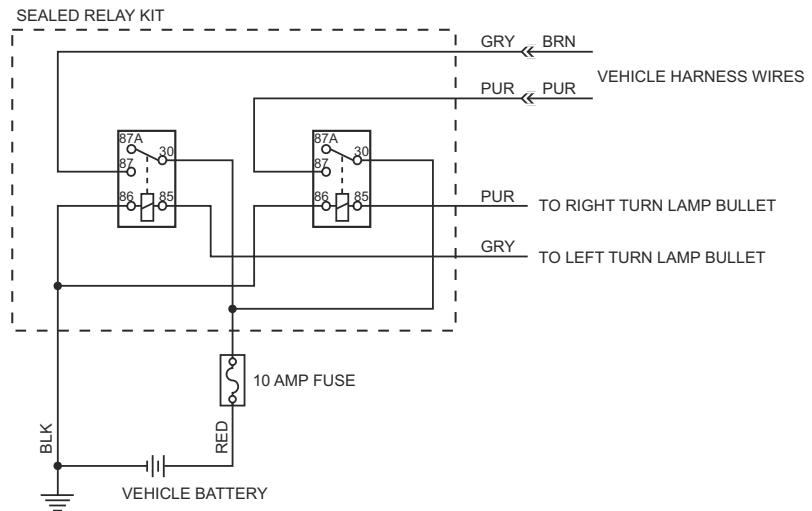

VEHICLE HEADLAMP TEST – 12-PIN HARNESS – 3 RELAY SYSTEM ONLY

1. Verify correct harness and wire installation to headlamp relays, vehicle headlamps, and vehicle headlamp connectors.
2. All bulbs must be good.
3. Disconnect all harnesses at the front of the vehicle.
4. Turn vehicle headlamp switch on. For vehicles with Daytime Running Lamps (DRL's), turn ignition on. DRL equipped vehicles have a pink wire instead of a brown wire on relay terminal 86.
5. Verify power for both high and low beam and ground are present at the original vehicle headlamp connectors.
6. Refer to the Electrical Schematic – 12-Pin Harness, and the Headlamp Test Diagram – 12-Pin Harness. The specific wiring diagram for the vehicle can be found in the plow installation instructions, or the manual *Electrical Schematics Guide*.

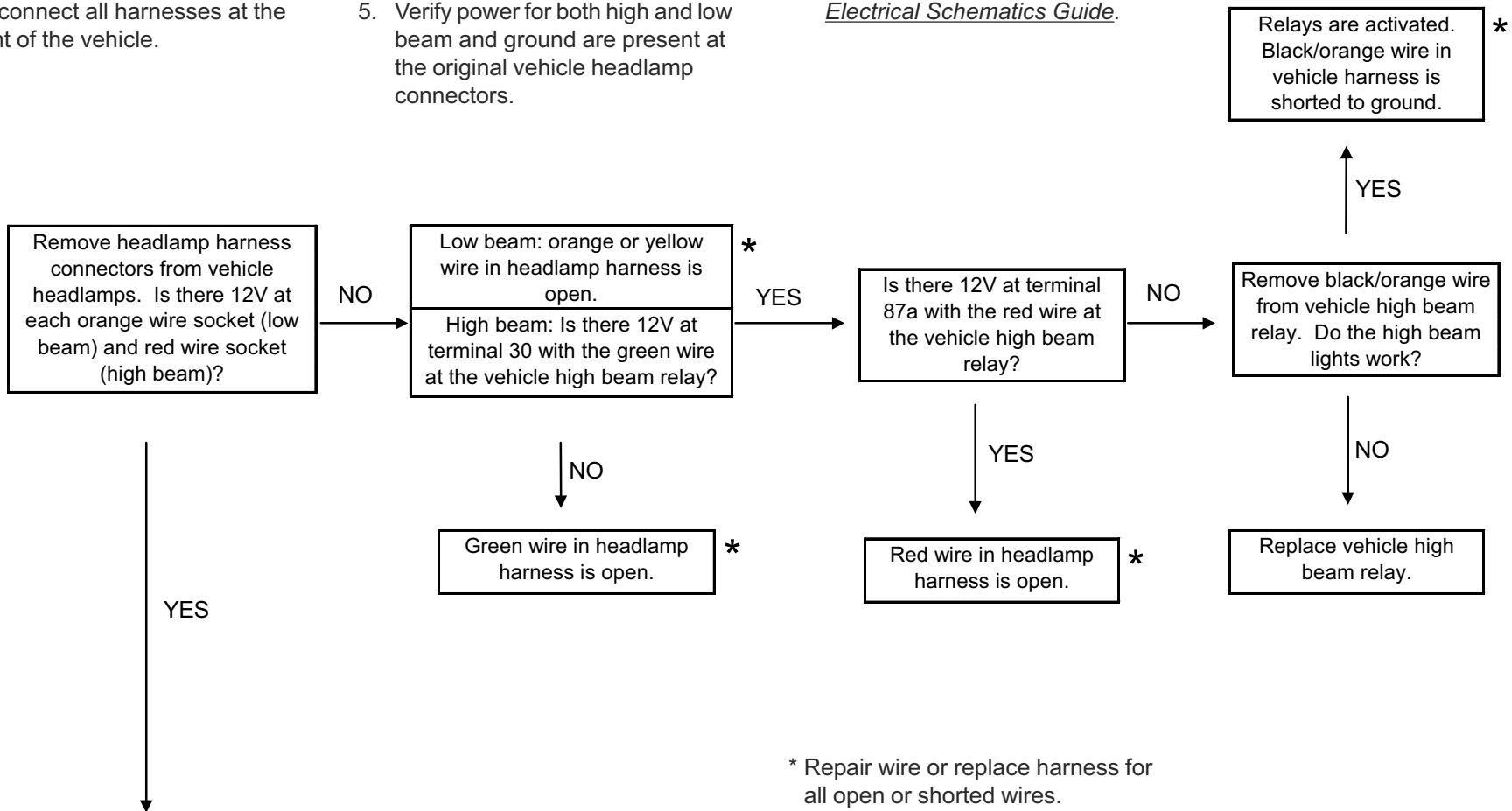

VEHICLE HEADLAMP TEST – 12-PIN HARNESS – 3 RELAY SYSTEM ONLY

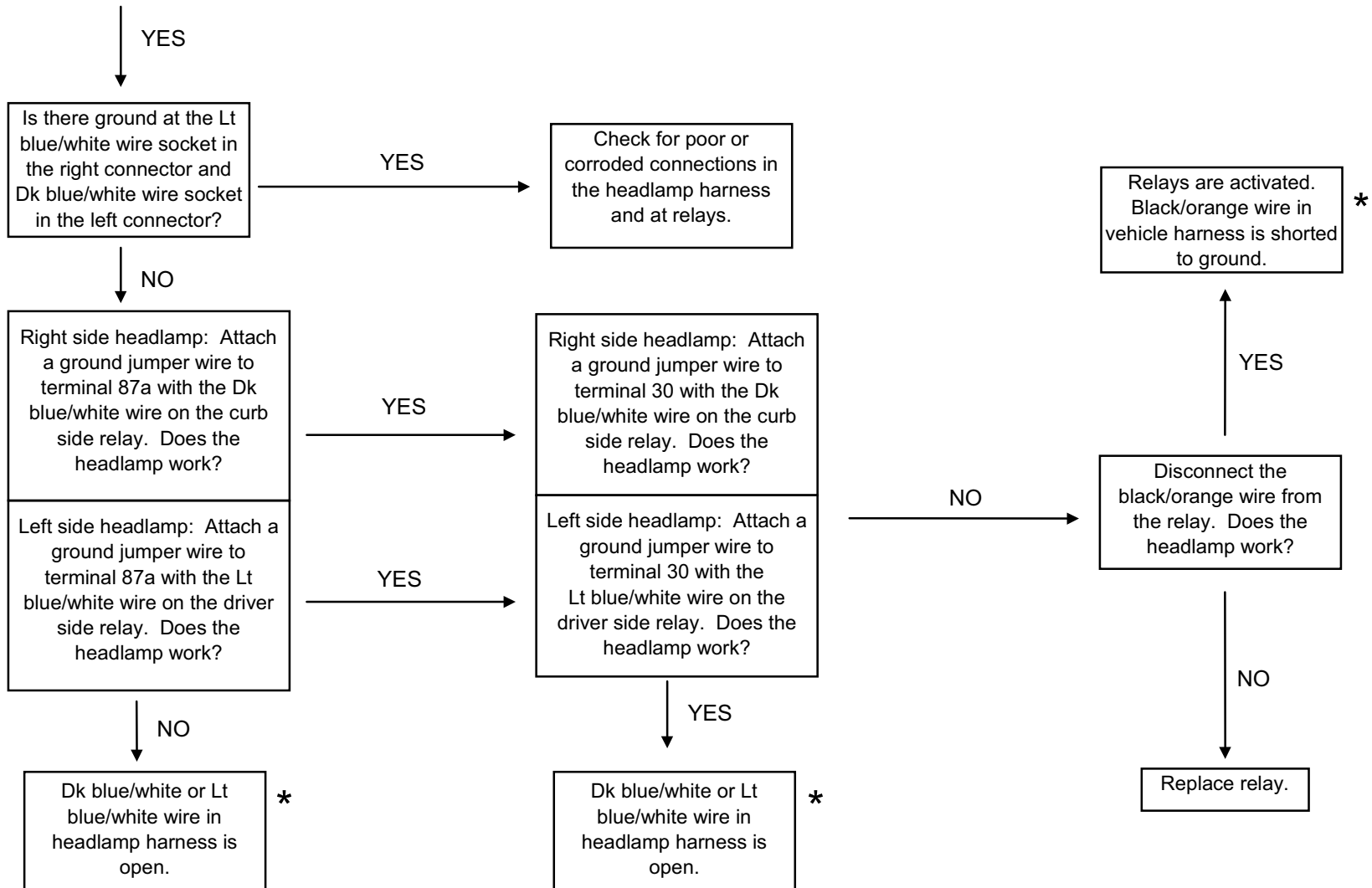

* Repair wire or replace harness for all open or shorted wires.

PLOW HEADLAMP TEST – 12-PIN HARNESS – 3 RELAY SYSTEM ONLY

1. Verify correct harness and wire installation to headlamp relays, vehicle headlamps, and vehicle headlamp connectors.
2. All bulbs must be good.
3. Connect all harnesses at the front of the vehicle.
4. Turn vehicle headlamp switch on. For vehicles with Daytime Running Lamps (DRL's), turn ignition on. DRL equipped vehicles have a pink wire instead of a brown wire on relay terminal 86.
5. Verify power for both high and low beam and ground are present at the original vehicle headlamp connectors.
6. Refer to the Electrical Schematic – 12-Pin Harness, and the Headlamp Test Diagram – 12-Pin Harness. The specific wiring diagram for the vehicle can be found in the plow installation instructions, or the manual *Electrical Schematics Guide*.

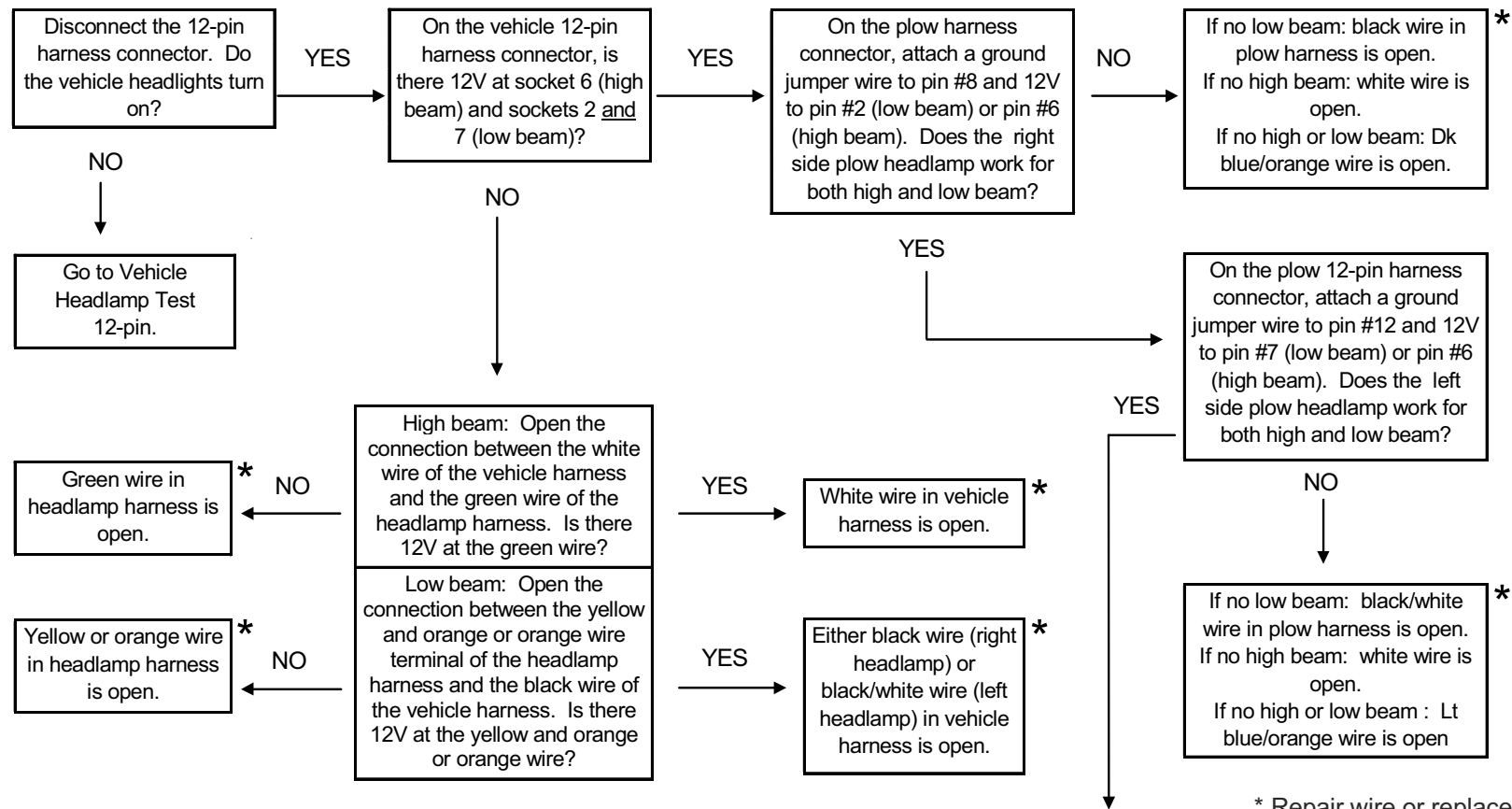

* Repair wire or replace harness for all open or shorted wires.

PLOW HEADLAMP TEST – 12-PIN HARNESS – 3 RELAY SYSTEM ONLY

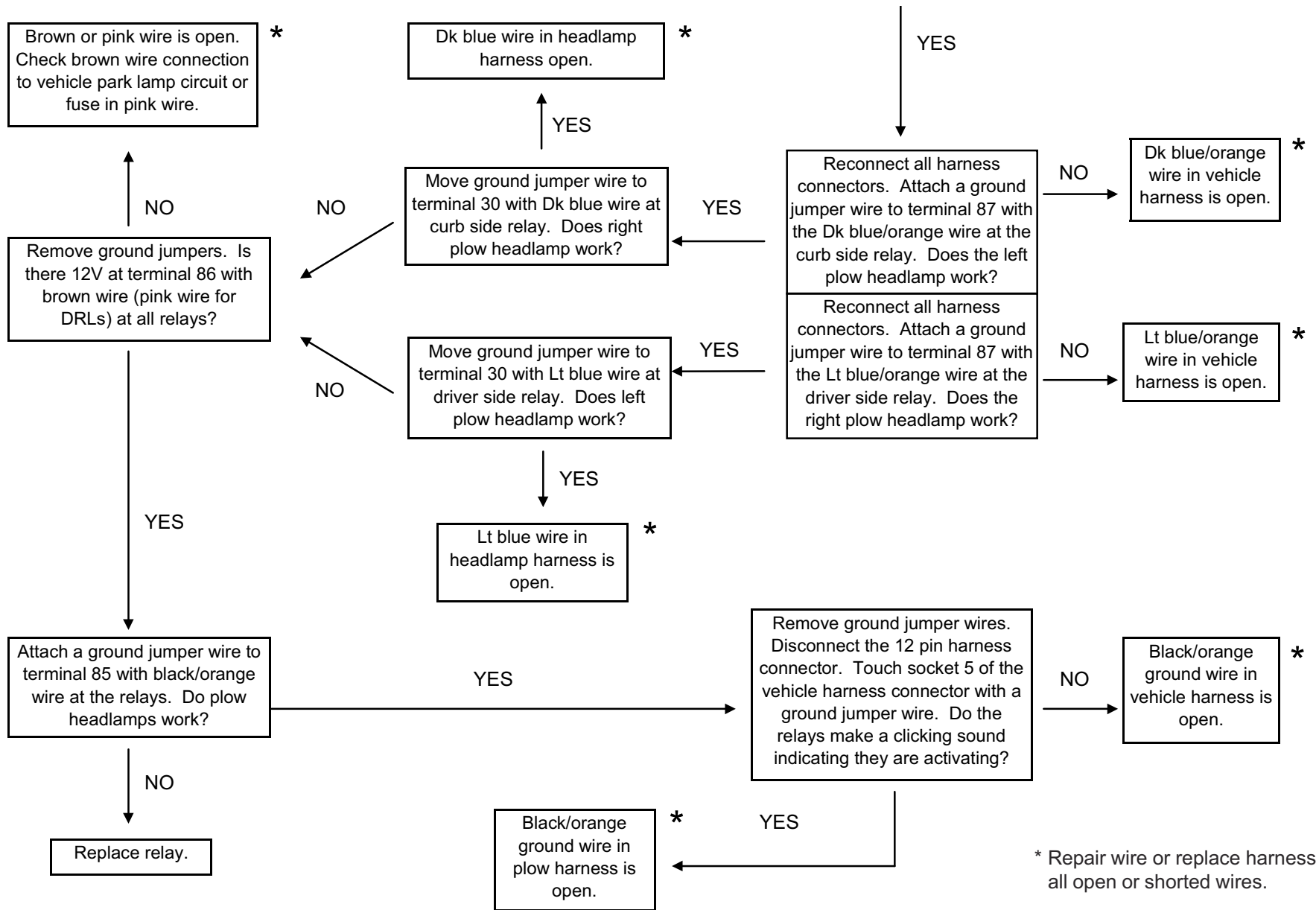

HEADLAMP TEST DIAGRAM – 12-PIN HARNESS – 3 RELAY SYSTEM ONLY ('98 AND OLDER VEHICLES)

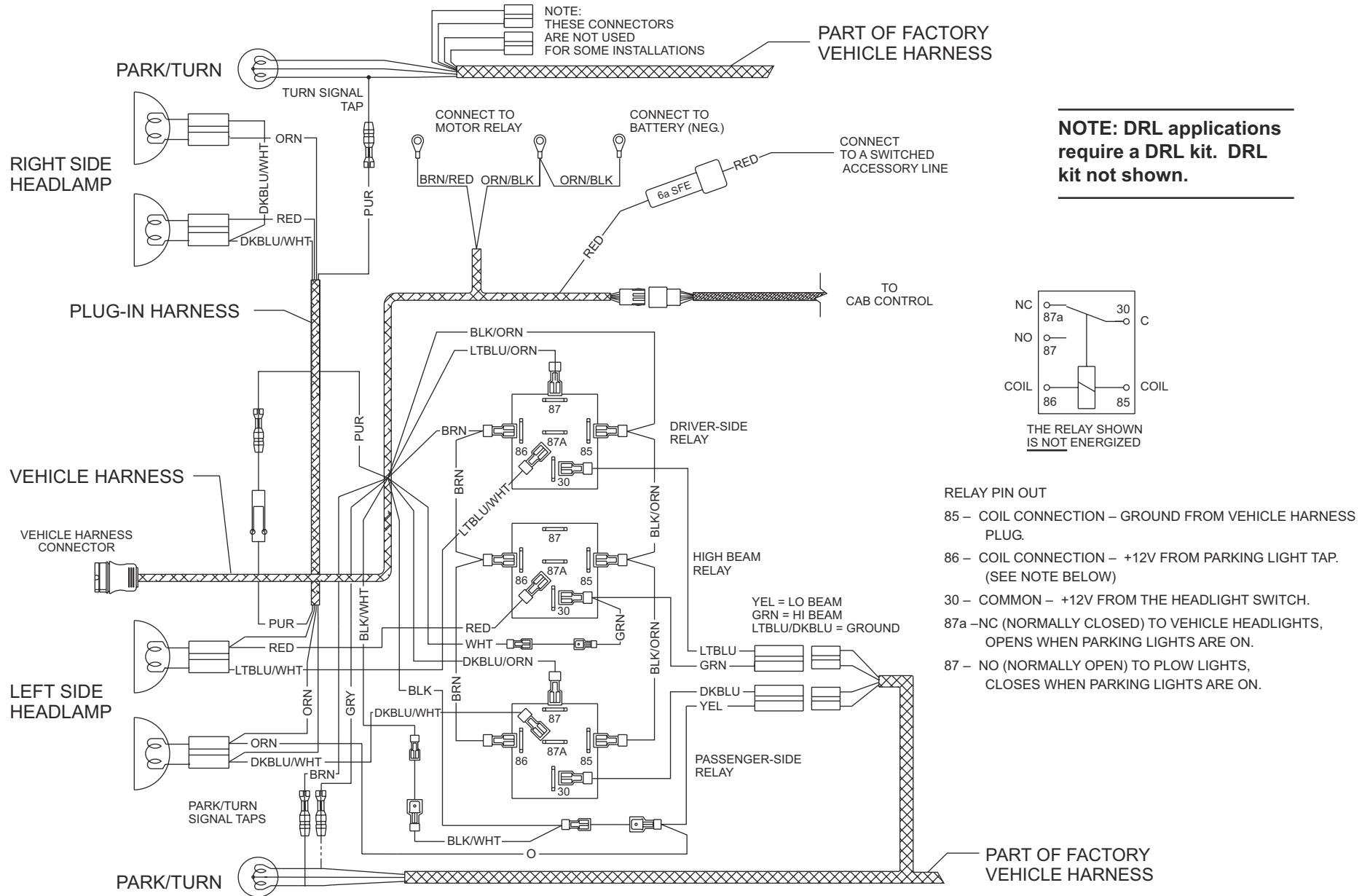

NOTES



WESTERN PRODUCTS
P.O. BOX 245038
MILWAUKEE, WI 53224-9538

↻ A DIVISION OF DOUGLAS DYNAMICS, L.L.C.

Copyright © 2003 Douglas Dynamics, L.L.C. All rights reserved. This material may not be reproduced or copied, in whole or in part, in any printed, mechanical, electronic, film or other distribution and storage media, without the written consent of Western Products. Authorization to photocopy items for internal or personal use by Western Products outlets or snowplow owner is granted.

Western Products reserves the right under its product improvement policy to change construction or design details and furnish equipment when so altered without reference to illustrations or specifications used. Western Products and the vehicle manufacturer may require and/or recommend optional equipment for snow removal. Do not exceed vehicle ratings with a snowplow. This product is manufactured under the following US patents: 4,999,935; 5,420,480; 5,806,213; 5,806,214; 6,145,222; 6,209,231; 6,253,470; 6,526,677; RE 35,700; CAN 2,060,425; and other patents pending. Western Products offers a limited warranty on all snowplows and accessories. See separately printed page for this important information. The following are registered (®) or unregistered (™) trademarks of Douglas Dynamics, L.L.C.: FloStat®, PRO PLUS™, UltraMount®, UniMount®, WESTERN®.

Printed in USA